



DELIVERABLE D3.5

Standard update

The StasHH standard, 2024 version

PUBLIC

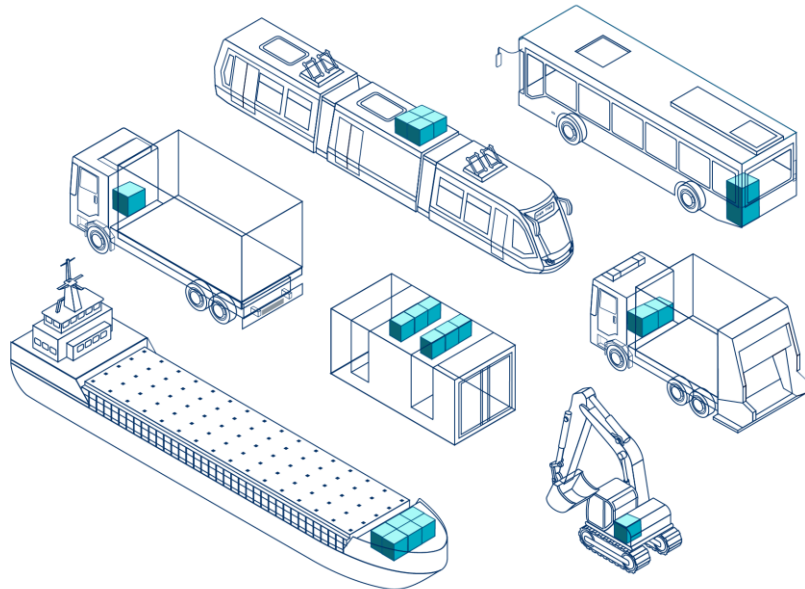

**Co-funded by
the European Union**

Ruud Bouwman (VDL), Henrik Lundkvist (SINTEF)
Quality Assurance: Federico Zenith (SINTEF)



Towards a standardised fuel cell module

Project acronym:	STASHH
Project title:	Standard-Sized Heavy-duty Hydrogen
Project number:	101005934
Call:	H2020-JTI-FCH-2020-1
Topic:	FCH-01-4-2020
Document date:	February 25, 2025
Due date:	June 30, 2024
Keywords:	Standard Sized, Fuel Cell, Fuel Cell Module, FC stack, FC Balance of Plant, CAN bus, Interface, Functional Safety, Protocol
Abstract:	This document describes the StasHH Fuel Cell Module Standard for external size, position of connection areas, connection principles, and digital interface for communication with an electronic control unit. This standard is written for PEM FC, but can be adapted to other FC technologies. The communication protocol is primarily intended for CAN bus, and it reuses messages from the SAE J1939 to be convenient for integration with existing applications.

Revision History

Date	Description	Author
2022/Jan/19	Completed D3.2 and D3.3	Ruud Bouwman (VDL)
2022/Jan/23	Quality assurance D3.2 & D3.3	Federico Zenith (SINTEF)
2022/Jan/25	Final D3.4 version	Henrik Lundkvist (SINTEF)
2022/Aug/18	Corrected PGNs, SPNs, and signal name.	Henrik Lundkvist (SINTEF)
2024/May/27	Updated parameter groups. Added hydrogen supply control and HV supply request.	Henrik Lundkvist (SINTEF)
2024/Aug/16	Updated PGNs and SPNs for hydrogen pressure parameters.	Henrik Lundkvist (SINTEF)
2024/Sep/2	Update D3.2 and D3.3 for D3.5, include AAA factor and peak/continuous power	Ruud Bouwman (VDL)
2024/Sep/4	Update for D3.5. Deleted appendix. Added table of figures and tables.	Henrik Lundkvist (SINTEF)
2024/Sep/12	Merged documents into single D3.5	Federico Zenith (SINTEF)

This project has received funding from the Fuel Cells and Hydrogen 2 Joint Undertaking (now Clean Hydrogen Partnership) under Grant Agreement No 101005934. This Joint Undertaking receives support from the European Union's Horizon 2020 Research and Innovation programme, Hydrogen Europe and Hydrogen Europe Research.

Any contents herein reflect solely the authors' view. The FCH 2 JU and the European Commission are not responsible for any use that may be made of the information herein contained.



Towards a standardised fuel cell module

Table of Contents

A	Physical Size.....	5
A.1	Introduction	5
A.2	Key-Terminology and StasHH goal	6
A.3	StasHH definitions.....	7
A.4	Requirements and KPIs for different applications	13
A.5	Conclusion.....	15
B	Physical Interfaces.....	16
B.1	Introduction	16
B.2	Key-Terminology and StasHH goal	17
B.3	StasHH definitions.....	18
B.4	Conclusion.....	22
C	Communication Interface.....	23
C.1	Introduction	23
C.2	Requirements.....	24
C.3	Standards and Architecture	28
C.4	Diagnostics and Prognostics	32
C.5	Interface Specification	34
C.6	Physical Connectors	65
C.7	Implementation over Ethernet	67
C.8	Conclusion.....	67

Abbreviations

AC	Alternating Current
API	Application Program Interface
APU	Auxiliary Power Unit
ASTM	American Society for Testing and Materials
BoP	Balance of Plant
CAN	Controller Area Network
CAN-FD	Controller Area Network – Flexible Data Rate
CRC	Cyclic Redundancy Check
CRM	Critical Raw Material
DC	Direct Current
DM1	Diagnostic Message 1
DTC	Diagnostic Trouble Code
ECU	Electronic Control Unit
FCCU	Fuel Cell Control Unit
FCM	Fuel Cell Module
HV	High Voltage
HVIL	High Voltage Interlock Loop
IP	Intellectual Property
ISO	International Organization for Standardization
LEL	Lowest Explosive Limit
LDV	Light-Duty Vehicle
LV	Low Voltage
OCV	Open Clamp Voltage
OEM	Original Equipment Manufacturer
PEM	Proton-Exchange Membrane
PG / PGN	Parameter Group / PG Number
PGM	Platinum-Group Metal
RCS	Regulations, Codes & Standards
SAE	Society of Automotive Engineers
SP / SPN	Suspect Parameter / SP Number
UN/ECE	United Nations Economic Commission for Europe

A Physical Size

A.1 Introduction

A.1.1 Document overview

Task 3.5 as defined in the StasHH Grant Agreement:

VDL will update the standards developed in the first year of the project with the experience gained during construction of FCMs, testing and feedback obtained from industry and RCS bodies. SINTEF and AVL will support VDL for the update of the digital interface.

A.1.2 StasHH objectives

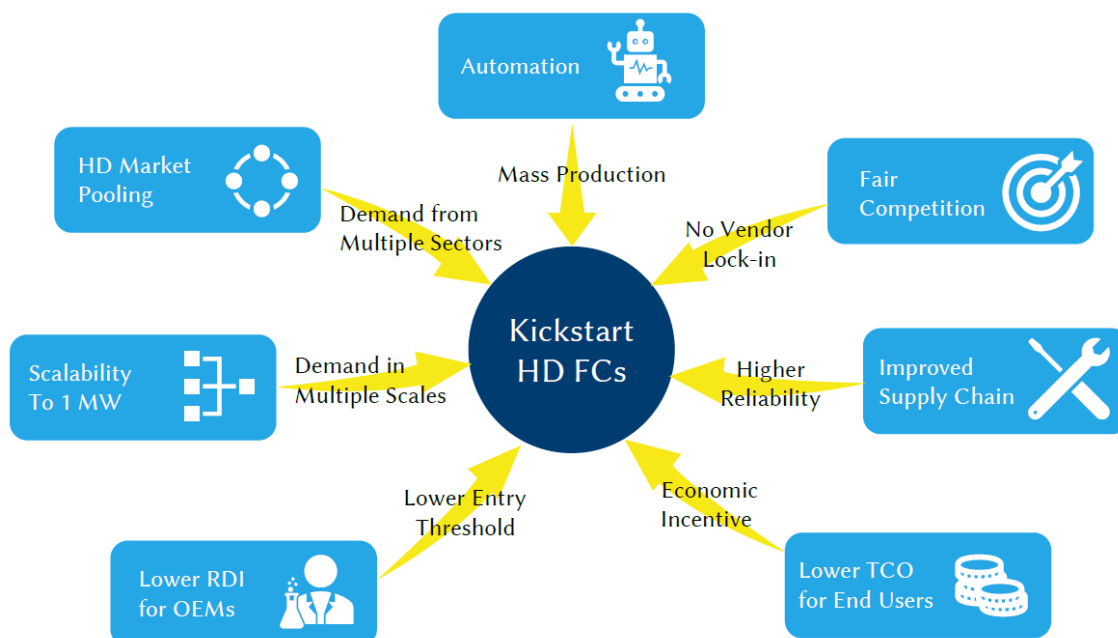

Figure 1: StasHH' specific objectives and their contribution to the overall objective

A.1.3 Scope of deliverable D3.5

This report is the outcome of the standard development workshops of WP3, including the comments from the latest workshop in June 2024 and e-mails on this subject and some clarifications. The objective of this document is defining the current status (09/2024) of the "Standard Definition".

A.1.4 Responsibilities

VDL is responsible for this document, with the support of the FCM suppliers and OEMs in this project.

A.2 Key-Terminology and StasHH goal

The StasHH project's paramount objective is to standardize the sizes of the fuel-cell (FC) **module**. The FC module is defined as the FC Stack and the Balance-of-Plant (BoP) components. The BoP consists of (at least) the air-supply system, the cooling system, the hydrogen recirculation system and the control system. Excluded are the hydrogen storage, the cooling radiator(s), the expansion tank, the filters, the exhaust (all of which are meant to be part of the vehicle) and the DC/DC converter. The DC/DC converter can optionally be integrated into the module. The FC module will act as subordinate and follow the requested power or current asked by the vehicle control system. The module must be intrinsically safe.

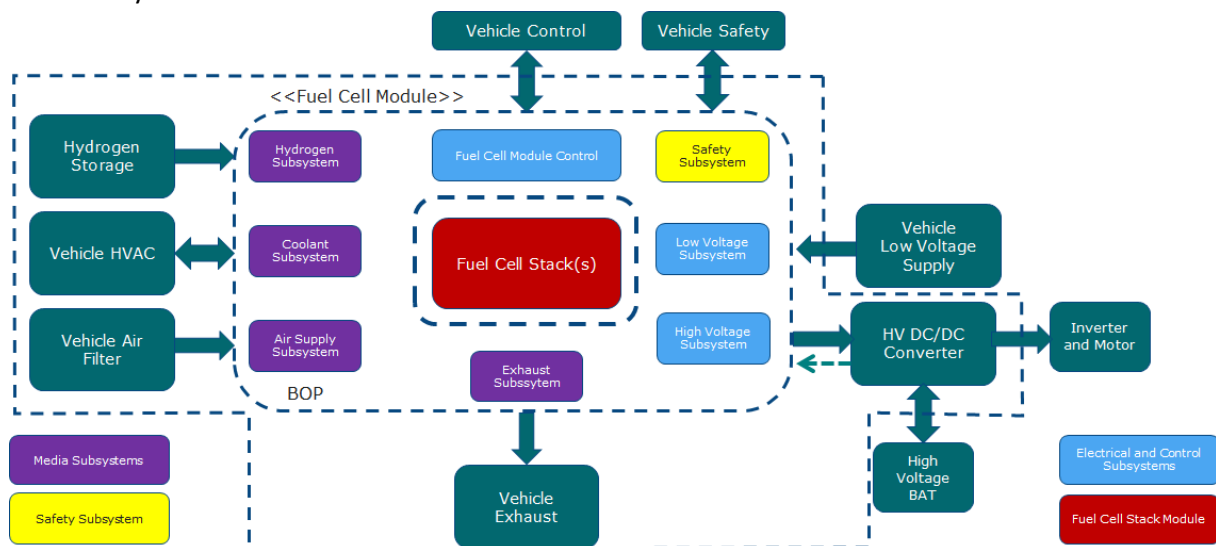

Figure 2: Key Terminology

The goal of WP3.5 in the StasHH project is to define the:

- Standard Size (outside) (D3.5/3.2 chapter 3.2)
- Interface area(s) (incl. position) (D3.5/3.3)
- Hydraulic and pneumatic interfaces (D3.5/3.3)
- Electrical interfaces (D3.5/3.3 and D3.5/3.4)
- I/O communication (D3.5/3.4)

Chapters A.3.3 “Serviceability” and A.3.5 “BoL and EoL” are not required for StasHH, but will be described in as proposal for further standardisation.

The StasHH definition should be a kind of overall specification that can be used by any OEM in any application. A high rate of interchangeability between the FC module manufacturers is the ultimate goal.

NOTE:

The IP background of the system architecture and components inside the defined Standard-Sized volume remains the property of the FC module manufacturer and is *not* part of this project. There will be therefore differences in used stacks, air-supply systems, etc.

A.3 StasHH definitions

A.3.1 Introduction

All the definitions are on dimensions and interfacing, and there are **NO** requirements concerning power or power density as long as it is above 30 kW (BoL).

A.3.2 Standard Size

There are three series of FC boxes defined, the A, the B and the C series. This is done together with the OEMs and the FCM. The A, B and C series are defined below (see also table 1). The triple A serie (AAA) is added:

- A or 1.020x700x340 mm (LxWxH)
- AA or 1.020x700x680 mm (LxWxH)
- AAA or 1.020x700x1020 mm (LxWxH)
- B or 1.360x700x340 mm (LxWxH)
- BB or 1.360x700x680 (LxWxH)
- BBB or 1.360x700x1.020 mm (LxWxH)
- C or 1.700x700x340 mm (LxWxH)

All dimensions are tolerated with 0/-100 mm.

The main points:

- Basic standard sizes:

Table 1: Fundamental FC module dimensions. The expected rating is only indicative and not a standard-mandated minimum.

StasHH	Length* mm	Width* mm	Height* mm	Expected PEM kW
A	1020	700	340	50
B	1360			70
C	1700			90

* Width, Height and Length are +0/-100 mm

- Derived standard sizes: each repetition of the letter “stacks” another module size. The industry has shown most interest in the following:

Table 2: Derived FC module dimensions. The expected rating is only indicative and not a standard-mandated minimum.

StasHH	Length* mm	Width* mm	Height* mm	Expected PEM kW
AA	1020	700	680	110
AAA			1020	160
BB			680	145
BBB	1360		1020	220

* Width, Height and Length are +0/-100 mm



Towards a standardised fuel cell module

In principle other combinations are possible (BBBB, CC and so on) but the industry has not shown interest for these yet. Different sizes may be combined with specifications such as “AB” in which case it is understood that:

- The letters indicate the sizes from top to bottom
- Shorter modules will be aligned so that one end is aligned with the larger ones.

Any architecture with two units not aligned on one side may be realised with two separate single modules.

The maximum volumes of the different sizes given in m³ ranges from 0.243 to 0.971 m³ (or 243 to 971 litres):

- A external volume is max. 0.243 m³
- AA external volume is max. 0.486 m³
- AAA external volume is max. 0.729 m³
- B external volume is max. 0.324 m³
- BB external volume is max. 0.647 m³
- BBB external volume is max. 0.971 m³
- C external volume is max. 0.405 m³



Co-funded by
the European Union

Towards a standardised fuel cell module

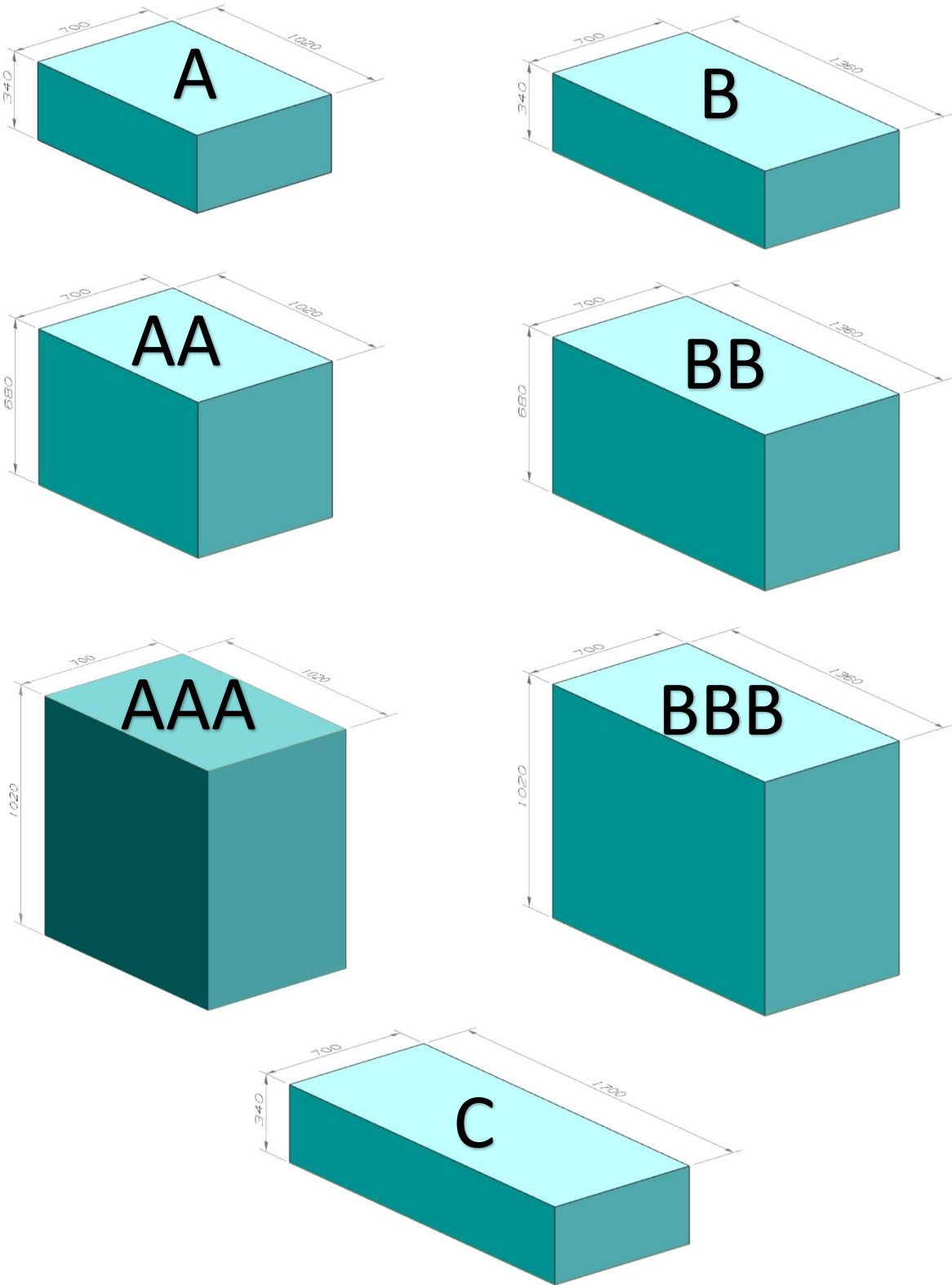

Figure 3: FC modules: A, B and C base and derived form factors

The A(A) can be orientated on its side (optional) for special applications (*not* a StasHH requirement).

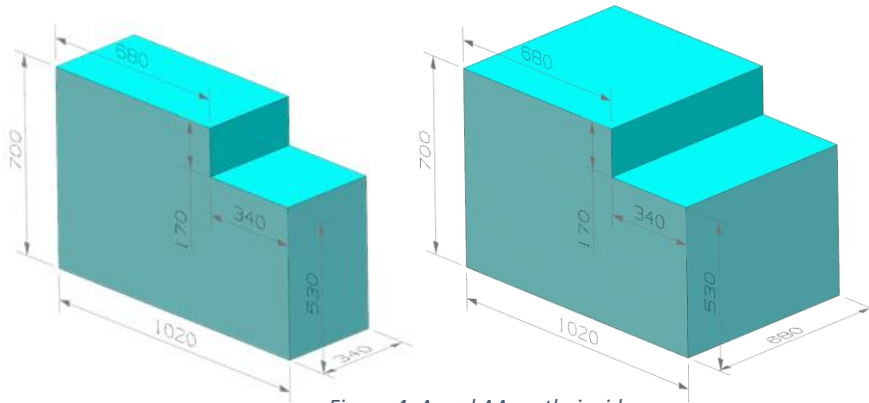

Figure 4: A and AA on their side

For the A(A) there were initially 7(14) proposals, for the B(B)(B) 5 and for the C 7. The FCM manufacturers, have built the A(A) (70%) and the B(B)(B) (30%) versions.

The ABC versions can be used in engine bays (trucks, buses and construction equipment), at the location where now the diesel tanks are situated, in GenSets, but also on the roof or underfloor for trailers and train wagons (for example for auxiliary power). A list with possible applications of the different sizes is shown in the next table and shared with the OEMs in December 2021.

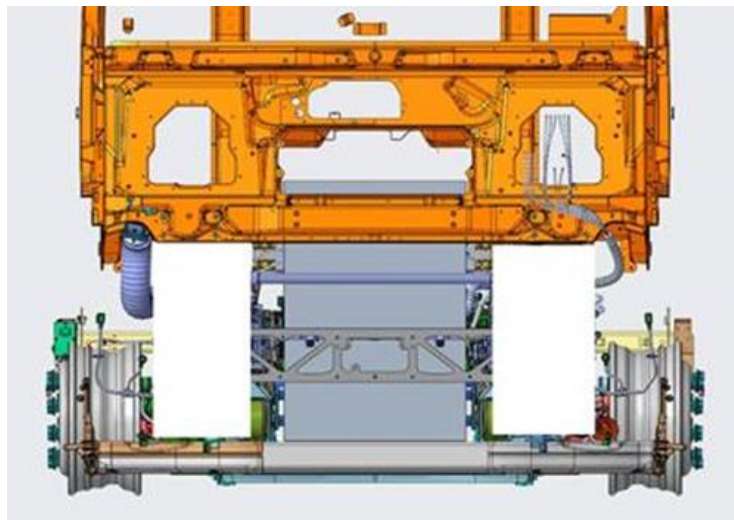

Figure 5: BBB in engine bay (Example)

Table 3: ABC applications

Application		StasHH Standard
(Semi-) Stationary	Container	A or AA(A)(horizontal or vertical) (multiple) or B(B)(B), C (horizontal)
	GenSet	A or AA(A) (horizontal or vertical) (multiple) or B(B)(B), C (horizontal)
	APU	A, B or C
Rail	Train Engine compartment Roof or Underfloor	BBB (multiple) A, B or C (multiple)
Water	Small Ships Engine compartment	BB or BBB
	Inland Ships Engine compartment	A or AA(A) (horizontal or vertical) (multiple) or B(B)(B), C (horizontal)
	Deck	Container
	Short Sea Shipping Engine compartment	A or AA(A) (horizontal or vertical) (multiple) or B(B)(B), C (horizontal)
	Deck	Container
	Special Ships Engine compartment	A or AA(A) (horizontal or vertical) (multiple) or B(B)(B), C (horizontal)
	Deck	Container
Off-Road	Construction equipment	Depending on vehicle
	Wheel loader Engine Bay	AAA, BBB or C (multiple, up to 3)
	Excavator Engine Bay	All possible
Road	Truck <44T (DAF-VOLVO-Iveco) Engine compartment Diesel tank area	AAA or BBB 2 AA or BB (Left and Right)
	Truck >18T and <26T Engine compartment Diesel tank area	AAA, BB or BBB 1 (or 2) AA or BB (Left and/or Right)
	Trailer (APU) Under Floor	A, B, or C
	City-Bus (12 or 18m) Engine compartment Roof or Underfloor	AA or BB 1 (or 2) AA 1 (or 2) BB or 1 C
Regional-Bus (12 or 18m) Engine compartment Roof or Underfloor	AA, AAA, BB or BBB 2 A , 2 B or 1 (or 2) C	
Coach (>=12m) Engine compartment	AA, AAA, BB or BBB	
	LDV and Car	Integrated solutions

A.3.3 Serviceability

Foreseen for 2022:

- Test connector
- Repair tree
- List with diagnostic codes

A.3.4 Power definition

The standard foresees two definition of power rating for a module, *continuous* and *peak*:

- **Continuous power** is the power that the module can deliver indefinitely as long as nominal operating conditions are maintained (hydrogen and air inflow, cooling rate, pressure, etc.)
- **Peak Power** is the power that the module can deliver for at least 60 seconds, which can be used for accelerating or for starting up machines.

Both power ratings can be mentioned by the FC supplier. If nothing is specified, the indicated power will be understood as continuous power.

A.3.5 BoL and EoL

The definition of Beginning of Life (BoL) and the End of Life (EoL) can be very different depending on the intended application. The definitions must be consistent and based on practical use of the FC module. A compromise on this could be the next definitions:

- BoL will be used for first testing and for comparison.
- To define the EoL, consider:
 - P_e^{\max} , the maximum electric *continuous* power, in kW_e, at which the FCM can be used safely and reliably, and
 - P_T^{\max} , the maximum needed heat rejection power in kW_T (@T_{FC}) corresponding to P_e^{\max}EoL will be defined as when the module is no longer able to continuously provide P_e^{\max} without exceeding cooling capacity P_T^{\max} .

With these values, a FC module application can be designed by the OEM.

- **“Service life” is the number of hours after which the FC reaches the EoL.**
- It is possible to supply a graph between kW_e and kW_T @BoL and EoL hours (See example below in Figure 6)

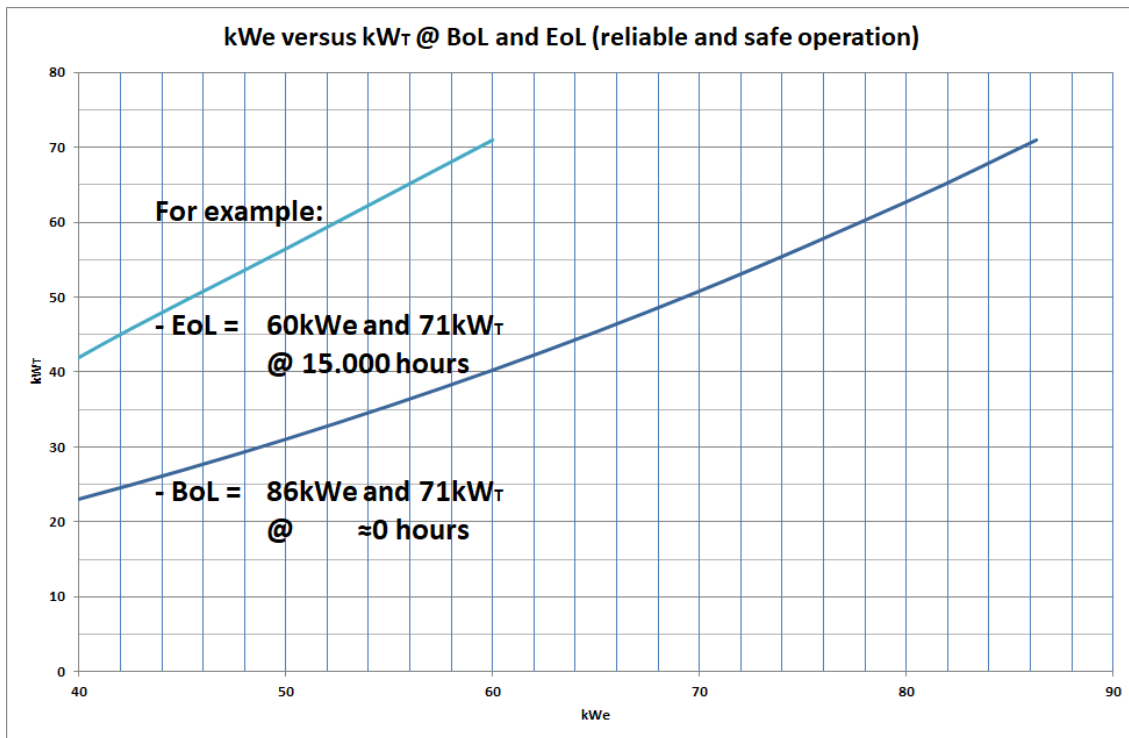

Figure 6: Example BoL and EoL curves

A.4 Requirements and KPIs for different applications

The “Requirements and KPIs” are divided in three categories:

- 1- The mandatory requirements according StasHH (Table 3)
- 2- The Norms and Standards for the different applications (See WP6)
- 3- The KPIs from the “Multi-Annual Work Plan 2021-2027” from Clean Hydrogen Joint Undertaking for the different applications (Table 4). The black figures in the table are official, the red ones are expected values

Table 4: Mandatory Requirements

Requirements		General
	PEM	
Service Life	h	> 15,000
Altitude	m	< 3000m with derating
IP	class	> 54
Low Voltage	V	24 V _{DC}
Output	V	160-850 V
Ambient T	°C	-25 to +45
Conductivity Glycol	μS/cm	< 6 (ASTM D 1125)
Hydrogen Input	bar	6 - 22
Hydrogen Quality	-	ISO 14687 (D), SAE J2719



Co-funded by
the European Union



Towards a standardised fuel cell module



Table 5 (3 Sections): KPIs for different applications (still as draft)

PEMFC-Mobility 1		Year	Heavy Duty	Maritime	Train	Aviation
Capex FC System (Excluding Storage)	€/kW	2020	1500	2000	-	
		2024	< 480	1500	-	
		2030	< 100	1000	< 50	
Availability	%	2020	85	94	94	85
		2024	95	97	97	95
		2030	98	>99	>99	98
Durability	hours	2020	15,000	20,000	15,000	15,000
	@nominal power	2024	20,000	40,000	20,000	20,000
		2030	30,000	80,000	30,000	30,000
Nr. Starts	-	2020	5000		5000	
		2024	12,000		12,000	
		2030	30,000		30,000	
Power Rating	kW	2020	200	500		-
	@max power	2024	300	3000		23 MW
		2030	-	10,000		46-82 MW
Power Density	kW/ton	2020	250		-	750
	@max power	2024	350		135	1000
		2030	>400		>160	2000

PEMFC-Mobility 2		Year	Heavy Duty	Maritime	Train	Aviation
Volumetric Density	kW/m ³	2020	150	15	-	
	@max power	2024	250	25	53	
		2030	>300	30	60	
Hydrogen Consumption	kgH ₂ /100km/ton	2020	0,30		0,12	-
	@nominal power	2024	0,27		0,11	0,70
		2030	0,24		0,08	1,40
Fuel Flow	kgH ₂ /hour	2020	12	30		-
	@max power	2024	18	180		1400
		2030	-	600		2800-5000
System Efficiency	%	2020	50,0	re-use heat	50,0	43,5
	@nominal power	2024	53,0		53,0	45,0
		2030	56,0		56,0	50,0
Areal Power/Density	W/cm ² @ V	2020	1.0 @ 0.650	-	-	-
		2024	1.0 @ 0.675	1.0 @ 0.675	1.0 @ 0.675	1.0 @ 0.675
		2030	1.2 @ 0.675	1.2 @ 0.675	1.2 @ 0.675	1.2 @ 0.675
PGM loading	g/kW	2020	0,40	0,40	0,40	0,40
		2024	0,35	0,35	0,35	0,35
		2030	0,30	0,30	0,30	0,30



Co-funded by the European Union



PEMFC-Stationary		Year			
			< 5 kW _e	5-50 kW _e	51-500 kW _e
CAPEX	€/kW _e	2020	6000	2500	1900
		2024	5000	1800	1200
		2030	4000	1200	900
O&Mcost	€ct/kWh	2020	10	10	5
		2024	8	7	3
		2030	4	3	2
ElectricalEfficiency	%LHV @nominalpower	2020	50	45	50
		2024	50	50	52
		2030	56	56	58
Availability	%	2020	97	97	98
		2024	97	98	98
		2030	98	98	98
Warm-start time	sec	2020	60		
		2024	15		
		2030	10		
Degradation @ CI	%/1.000h @nominal power	2020	0.40		
		2024	0.20		
		2030	0.20		
Stack Production cost	€/kW _e	2020	400		
		2024	240		
		2030	150		
Non-recoverable CRM	mg/W _e	2020	0.10		
		2024	0.07		
		2030	0.01		

A.5 Conclusion

Mechanical Standards are described and defined in this document. It will still be a challenge to get a maximum of uniformity in the FC module regulations for the different applications, like mobility, maritime and rail (see WP6).

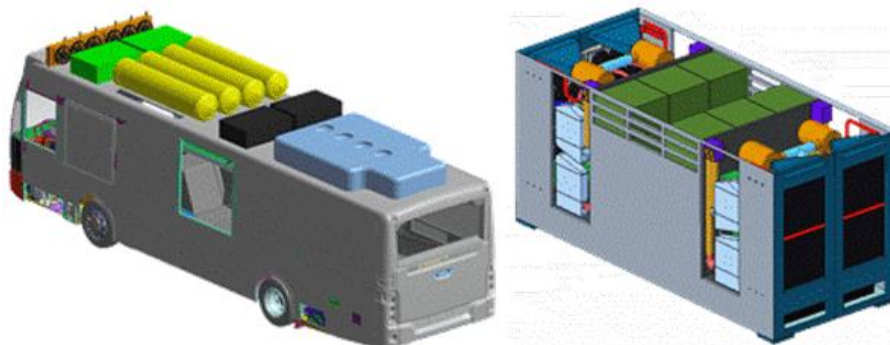

Figure 7: Example Bus and GenSet

B Physical Interfaces

B.1 Introduction

B.1.1 Document overview

Task 3.3 as defined in the StasHH Grant Agreement:

VDL will define the maximum size of the FC modules and their interface areas for the different power ranges with input from all **OEMs** for maximum available space claim and other relevant specifications for all applications. **VDL** will define other relevant physical specifications (mechanical, after-sales serviceability etc.) for the identified standard sizes, which will be validated by **FCM suppliers**.

B.1.2 StasHH objectives

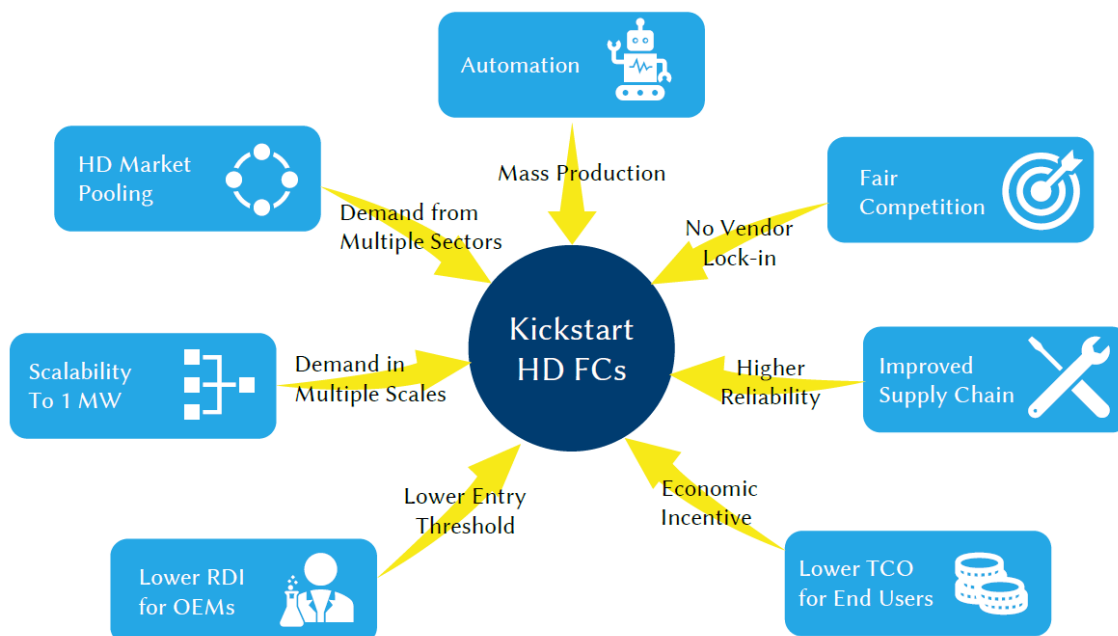

Figure 8: StasHH's specific objectives and their contribution to the overall objective

B.1.3 Scope of deliverable D3.5

This report is the outcome of the standard development workshops of WP3, including comments from the latest workshop in June 2024, e-mails on this subject and some clarifications. The objective of this document is defining the current status (09/2024) of the "Standard Definition".

B.1.4 Responsibilities

VDL is responsible for this document, with the support of the FCM suppliers and OEMs in this project.

B.2 Key-Terminology and StasHH goal

The StasHH project's paramount objective is to standardize the sizes of the Fuel Cell (FC) **module**. The FC module is defined as the FC Stack and the Balance-of-Plant (BoP) components. The BoP consists of (at least) the air-supply system, the cooling system, the hydrogen recirculation system and the control system. Excluded are the hydrogen storage, the cooling radiator(s), the expansion tank, the filters, the exhaust (all of which are meant to be part of the vehicle) and the DC/DC converter. The DC/DC converter can optionally be integrated into the module. The FC module will act as subordinate and follow the requested power or current asked by the vehicle control system. The module must be intrinsically safe.

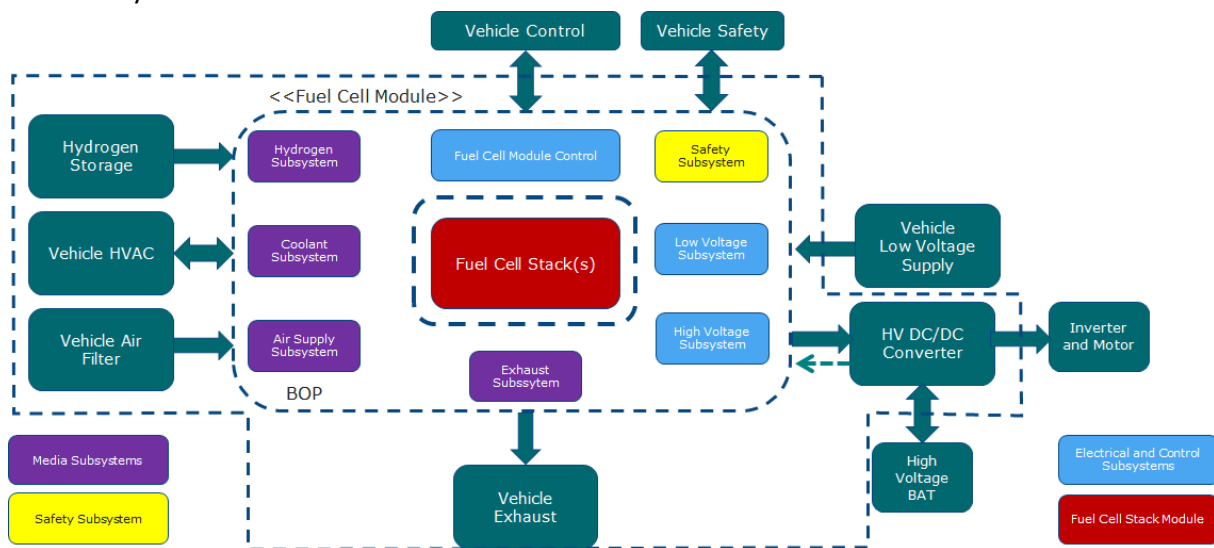

Figure 9: Key Terminology

The goal of WP3 in the StasHH project is to define the:

- Standard Size (outside) (A)
- Interface area(s) (incl. position) (B.3.2)
- Hydraulic and pneumatic interfaces (B.3.3)
- Electrical interfaces (B.3.4)
- I/O communication (C)

Chapters A.3.3 “Serviceability” and A.3.5 “BoL and EoL” are not required for StasHH but will be described as proposal for further standardisation.

The StasHH definition should be a kind of overall specification that can be used by any OEM in any application. A high rate of interchangeability between the FC module manufacturers is the ultimate goal. Further standardisation on connection area and hydraulic or pneumatic interfaces are discussable on the near future.

NOTE:

The IP background of the system architecture and components inside the defined Standard-Sized volume remains the property of the FC module manufacturer and is *not* part of this project. There will be therefore differences in used stacks, air-supply systems, etc.

B.3 StasHH definitions

B.3.1 Introduction

All the definitions are on dimensions and interfacing, and there are **NO** requirements concerning power or power density as long as it is above 30 kW (BoL).

B.3.2 Interface area

The interface area can be on two different sides. At least all pneumatic and hydraulic connections are within this interface area (except eventually the drain or (box) ventilation). Sides are defined with FC module in horizontal position.

- i. In corner 3, on the LxH side FC module. See Figure 10. The dimensions of the interface area will be max. 340mm x $Depth_{main}$ x Module Height
- ii. In corner 4, on the WxH side FC module. See Figure 10. The dimensions of the interface area will be max. 700mm x $Depth_{main}$ x Module Height

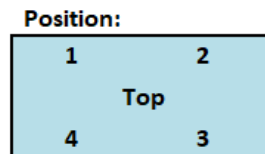

Figure 10: Top view FC module

“ $Depth_{main}$ ” or “ D_{main} ” is defined as the minimum depth needed to stay within the overall FC module volume (defined in A), with connected male and female connectors.

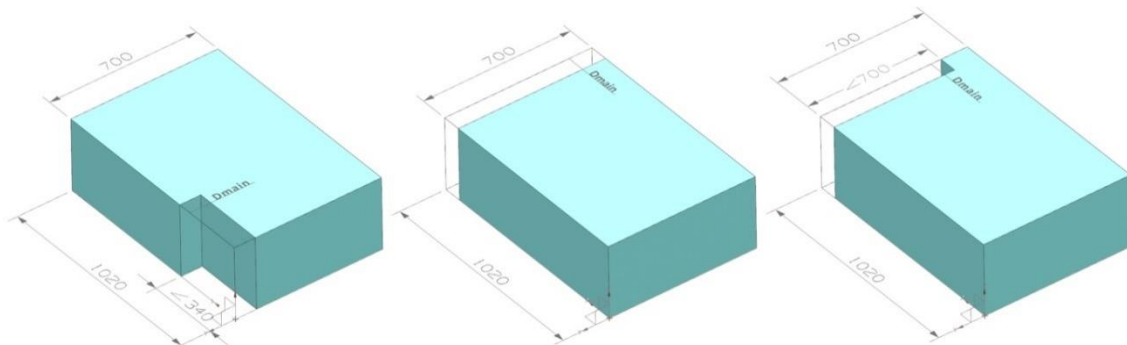

Figure 11: FC module interface areas possibilities (1st side)

Table 6: Dimensions FC module Interface areas (1st Side).

Interface 1 st Side LxH side	Length1 Distance from corner 3 mm	Depth1 _{main} mm	Height1 mm	Interface 1 st Side WxH side	Width1 Distance from corner 4 mm	Depth1 _{main} mm	Height1 mm
A	max 340	≥ D_{main} *	340	A	Max 700	≥ D_{main} *	340
AA			680	AA			680
AAA			1020	AAA			1020
B			340	B			340
BB			680	BB			680
BBB			1020	BBB			1020
C			340	C			340

* D_{main} is minimum depth needed to stay within overall FC module volume with connected interfaces

Conditions for optional use of two interface areas:

If used e.g. in a truck engine bay, the back side of the FC module is used for hydrogen, air and steam connections; the cooling hoses can be coupled on the front side of the FC module.

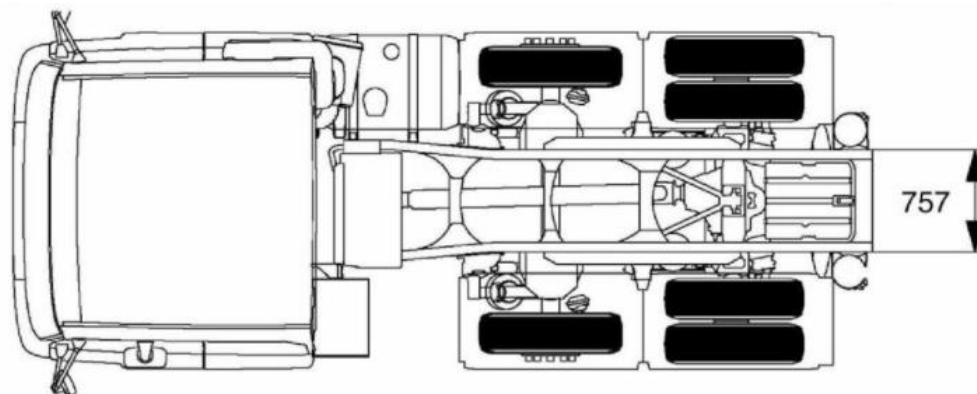

Figure 5: Example tractor 6x2

When this option is used, then:

- Either
 - a) The main side complies with i) with depth “ D_{main} ”, and the second side complies with ii) with depth “ D_{sub} ”
 - OR
 - b) The main side complies with ii) with depth “ D_{main} ”, and the second side complies with i) with depth “ D_{sub} ”
- Both connections areas are mechanically redundant, i.e., all pneumatic and hydraulic connections are on both sides (except eventually the drain or (box) ventilation)

“ $Depth_{sub}$ ” or “ D_{sub} ” is defined as the minimum depth needed to stay within the overall FC module volume (defined in A), with **not** connected male or female connectors.

Table 7: Dimensions FC module Interface area's (Optional 2nd Side).

Interface	Length2 or Width2	Depth _{sub}	Height2
2 nd Side	mm	mm	mm
A	Max 340 or 700	$\geq D_{sub}^x$	340
AA			680
AAA			1020
B			340
BB			680
BBB			1020
C			340

^x Depth_{sub} is min. depth needed to stay within overall FC module volume with **not** connected interfaces

See 2 examples in Figure 12, where the first interface area is max.(<)340x340 mm and the second interface area is max. (<)700x340 mm or 700x340 mm.

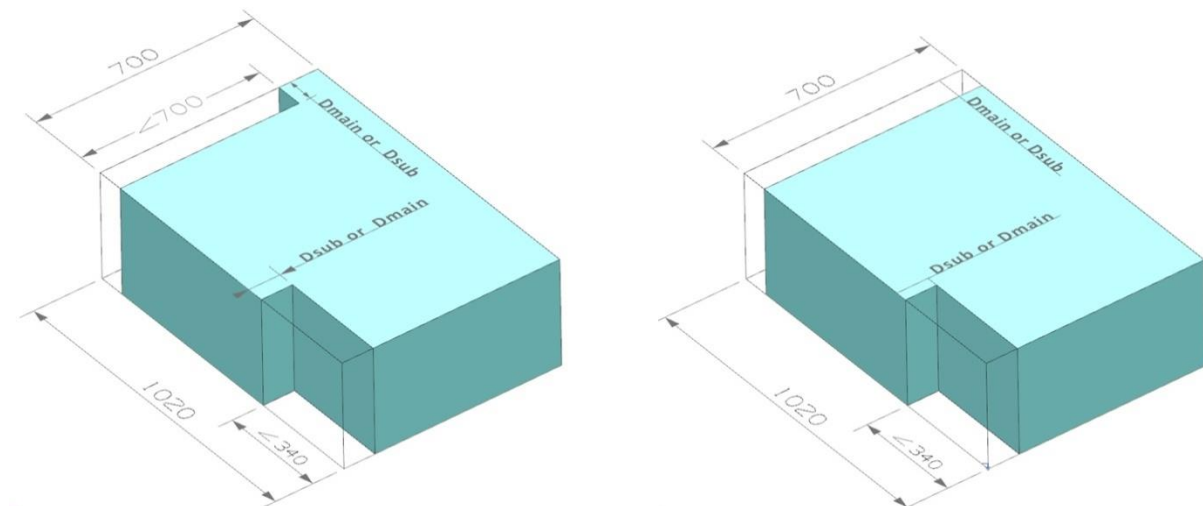

Figure 12: 2 examples FC module interface areas (1st side and optional 2nd side)

B.3.3 Hydraulic, Pneumatic and Electrical interfaces

The hydraulic and pneumatic interfaces must comply with the following rules:

- All the **pneumatic and hydraulic connections**, excluding the optional drain or (box) ventilation, are positioned in the defined interfaces areas of chapter B.3.2.
- The connections' principle will be fixed for all FCMs, but can be different depending on usage. For example, for air this can be a hose, for hydrogen a pipe. See Table 3
- The connection size ranges (in mm) are defined, but will vary with the power range of the FC module (see Table 3).

VERY IMPORTANT:

- The electrical and I/O communication can be positioned anywhere within the chosen overall ABC dimensions (see part A).

Table 8: Hydraulic and Pneumatic Interfaces FC module.

StasHH	Interfaces	Inner diameter[mm]				Remark
		Nominal Power				
		≤70kW	71-≤100kW	101-≤130kW	131-≤160kW	
Hydrogen	Pipe fitting (two ferrule)	6-8	8-12	12-16	16-20	6-22bar
Air	Nozzle+Hose	30-60	45-75	60-90	75-105	Optional
Steam	Nozzle+Hose	30-60	45-75	60-90	75-105	Optional
Drain	Nozzle+Hose	6-8	8-12	12-16	16-20	Optional
Cooling FC	Nozzle+Hose	20-40	30-50	40-60	50-70	In/Out
Cooling-E	Nozzle+Hose	15-35	20-40	25-45	30-50	Optional
Breather	Banjo	M14x1,5	M14x1,5	M14x1,5	tbd	Optional
Ventilation	Nozzle(+Hose)	20-40	20-40	20-40	20-40	Optional

Terminology:

- Hydrogen = Inlet Hydrogen
- Air = Inlet Air
- Steam = Outlet Exhaust Steam
- Drain = Outlet (optional, if needed)
- Cooling FC = Inlet, Outlet cooling system stack
- Cooling E = Inlet, Outlet cooling electronics (optional, if needed)
- Breather = Outlet, degassing from cooling system
- Ventilation = Ventilation (box)

- The main hydraulic and pneumatic connections (Hydrogen/Air/Steam/t Cooling) should not interfere in the horizontal and vertical directions (See Figure 13).

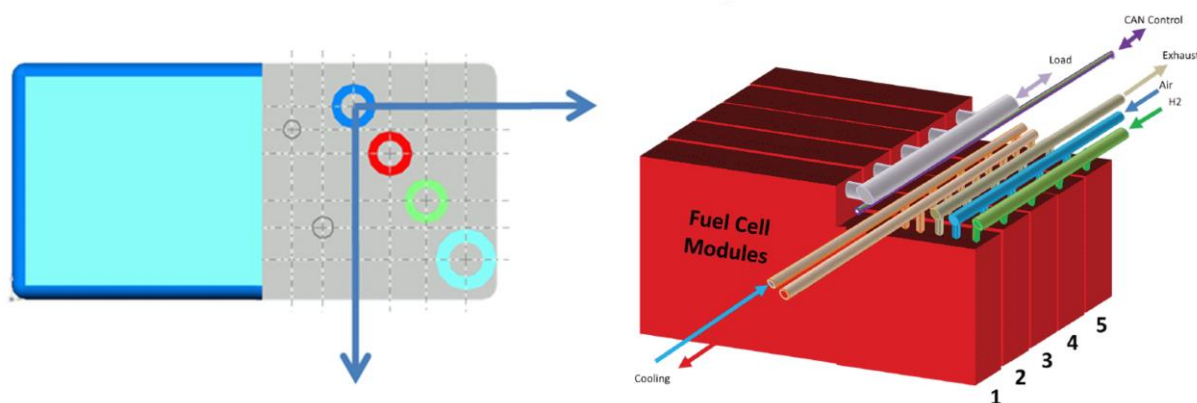

Figure 13: Non-interfering hydraulic and pneumatic connections

B.3.4 Low and High Voltage Connectors

The pins of the high voltage connectors will be specified, not the particular connector. For the high-voltage connector there are two pins, plus and minus. The chosen connector must withstand the maximum voltage and current of the FCM; the connector shown in Figure 14 is an example. A connector already used in heavy-duty applications is preferred.

The low-voltage connector has to withstand up to 100 A. As this is too much to integrate within the I/O connector, it is suggested to use cable lugs.



Co-funded by
the European Union

Towards a standardised fuel cell module

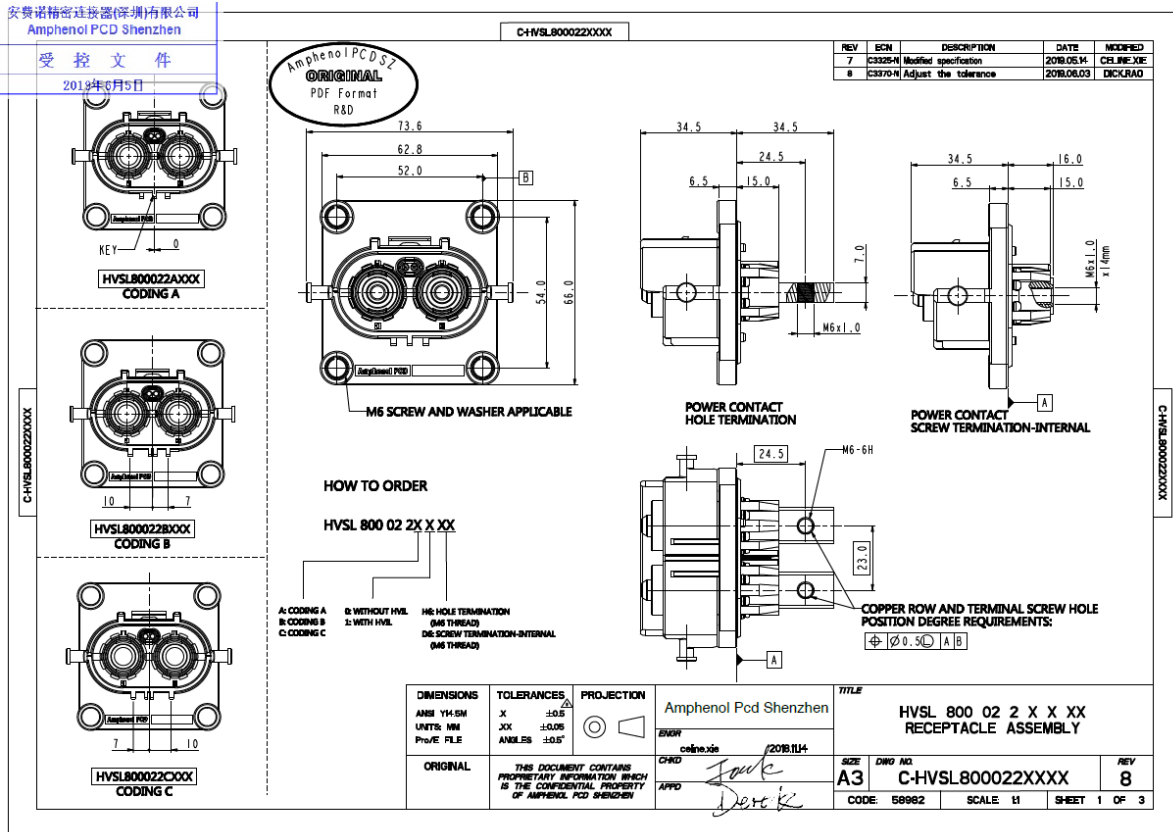

Figure 14: Example of HV interface connector

B.4 Conclusion

Mechanical, Pneumatic, Hydraulic, Electrical and Communication Standards are described and defined in this document. It will still be a challenge to get a maximum of uniformity in the FC module regulations for the different applications, like mobility, maritime and rail (see WP6).



Figure 15: Example Bus and GenSet



Towards a standardised fuel cell module

C Communication Interface

C.1 Introduction

This part of the standard covers the digital communication interface of the FCM. It has been going through a substantial update from the first version of the StasHH standard in D3.4. The main updates have been made to align with new parameters that have been included in the SAE J1939 standard, both independently and with input from the StasHH project. Some of the optional messages still re-use parameter groups that are not intended specifically for fuel cells, if these are used it should be considered to request SAE for inclusion of new fuel cell specific parameter groups.

A standardized fuel cell module has important benefits in terms of economies of scale, market competition and more efficient system development and operation. To reach a large market, the standard shall be useful for multiple applications, such as buses, trucks, trains, ships and stationary generators. However, designing a standard that address the requirements from several markets is more challenging than a narrower standard targeting a single market. The existing computing and communication platforms in different industries have to be taken into account, and a compromise between simple integration into existing applications and a general future-proof solution be found.

The digital interface concept was separated into 3 main topics, as shown in Figure 16. The layering allows for a reasonable modularity in the solution, such that it will be possible to have a common API that can interface to different lower layer protocols and connectors. Although it would be possible to start from a clean sheet and use a broad framework such as OPC UA, this would require significant work for OEMs to integrate the new standard with their existing systems. Therefore, StasHH takes a pragmatic approach that we believe will be the most efficient way to reach a market acceptance. We try to identify existing standards that can be reused and derive practical solutions as modifications and extensions to those standards. Considering that the truck and bus markets have a potential to drive the demand for large volumes of fuel cells, it is important to provide a solution that is useful for those OEMs. Hence, the existing CAN bus and J1939 standards that are very widely used in heavy duty vehicles has an advantage of providing an easier way to adoption by the truck and bus OEMs. This document is therefore accompanied by a CAN DBC file that has an accurate description of the signals in the messages. The DBC format was selected since it is a de facto standard and with multiple tools available.

The initial goal of the standard was to specify a single connector that would make the FCMs easily interchangeable. However, it is also considered importance to have a connector with multiple suppliers to avoid lock-in and problems with availability. Therefore, the standard primarily focuses on the pins while the specific connector to use is mainly specified in order to have a common connector within the project during testing.

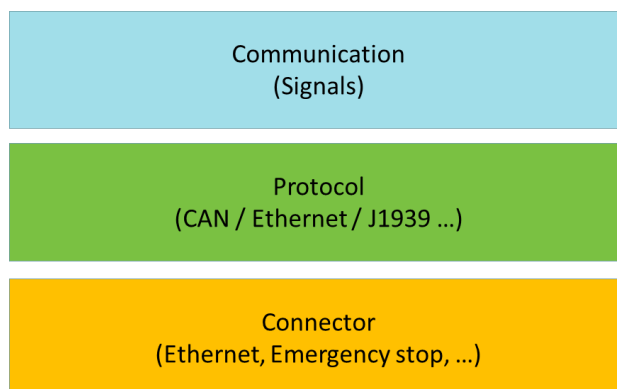

Figure 16. Layered concept of the digital interface.

C.2 Requirements

A mapping of the requirements on the interface has been done based on current implementations of the partners. The input showed that the level of maturity of the different implementations vary and that most of the design choices were still open in the sense that there was no strong consensus. A pragmatic approach is taken where we consider the possibility to adapt the system to the practical FCM implementation constraints rather than putting too strict requirements on the FCM.

In general, the digital interface is intended to support the basic operation of the FCM. With respect to the information that needs to be communicated there is therefore a common basis which can be agreed. The boundaries of the fuel cell module will in most cases include a DC/DC converter to convert the voltage from the fuel cell stack output to the required voltage of the HV bus.

With respect to the protocols, there is a natural preference to use protocols that are easy to integrate with existing systems. Due to the difference in existing systems between different sectors, it is difficult to fulfil all the preferences and a compromise is needed to be able to address a large market.

Due to different power stages of the systems the length of cables and number of FCMs that are needed in a system to deliver sufficient power can vary. There is a trade-off between the cable length and the achievable bitrate and latency, hence the standard shall not put higher requirements on the bit rate than necessary. It was agreed that a bit rate of 500 kb/s should be supported. The standard should not prevent CAN-FD from being used, although it is not mandatory for the FCM to support CAN-FD.

With respect to the physical connector, it has been agreed that the required ingress protection level is IP54. It is a preference to use a connector which can be provided by multiple suppliers. The number of pins and the signals they shall be used for has been analysed during the specification work, and the conclusion is that at least 7 mandatory pins should be available and another 7 optional pins are recommended. In addition, it is recommended to have some additional pins available for proprietary use and future extensions.

C.2.1 Safety and Security

Safety and security requirements from different application areas have been identified in StasHH work package 6. The standard and regulation documents require some interpretation to deduce the actual impact on the digital interface specification, therefore the most relevant documents for the digital interface have been reviewed based on the input from WP6. In the following subsections the

conclusions on the requirements for emergency stop, HVIL, cyber security and alarms are summarized with reference to examples from a subset of the relevant documents.

C.2.1.1 Emergency Stop

Most applications have a requirement on emergency stop functionality. For electric vehicles there is a need to fulfil safety criteria to avoid electrical shock in case of a crash, following the UN/ECE regulations 94, 95 and 137 for different types of crashes. The requirements imply that the HV bus shall be de-energized quickly, hence a fast and robust shutdown procedure shall be implemented in the FCM.

In IEC 62282-3-100 safety standards for stationary fuel cell power systems are defined. Regarding shutdown the standard states that:

If the fuel cell generator is provided with an integral single emergency stop device, or terminals for connection for a remote emergency stop device, the circuit shall prevent further power supply export in any mode of operation. /.../Plug-connected fuel cell generators do not require an emergency switching device if the plug can perform the same function.

For maritime applications there is also requirements on supporting emergency shutdown in case of a certain alarms. In the DNV Rules for Classification it is also stated that signals required for certain safety functions shall be hardwired.

To support the requirements, our interpretation is that a combination of a hardwired emergency stop signal and an emergency signal in the communication protocol will provide the necessary robustness.

C.2.1.2 High Voltage Interlock Loop

To avoid that the FCM is delivering power when it is not connected to the HV bus it is common to use HVIL which sends a low voltage signal through the HV connectors in a closed loop. When the HV connectors are not properly closed the LV circuit is broken such that the open HV circuit can be detected rapidly.

UN/ECE regulation no. 100, amendment related to vehicles with electric power train, includes requirements on high voltage connectors to protect from electric shock:

- *Connectors are allowed to be separated without the use of tools, if they meet one or more of the following requirements:*
 - *(a) They comply with paragraphs 5.1.1.1 and 5.1.1.2 when separated; or*
 - *(b) They are located underneath the floor and are provided with a locking mechanism; or*
 - *(c) They are provided with a locking mechanism. Other components, not being part of the connector, shall be removable only with the use of tools in order to be able to separate the connector; or*
 - *(d) The voltage of the live parts becomes equal or below 60 V DC or equal or below 30 V AC (rms) within 1 s after the connector is separated.*

Although there are multiple ways these could be fulfilled, HVIL is a common solution that is widely used and the preferred solution that is supported in the standard.



Towards a standardised fuel cell module

C.2.1.3 Cyber Security

UN/ECE regulation n° 155, cybersecurity for vehicles, contains a list of threats and mitigations that should be taken into account in vehicles. The regulation applies to vehicle manufacturers, which in turn need to consider the security of the components included in the vehicles. It must be avoided that the FCM opens new weaknesses that threatens the cyber security of the system as a whole. Since the vehicle manufacturer has the responsibility to maintain the security of the whole system it is preferable to rely on security mechanisms of the vehicle when possible.

This standard defines the communication between the FCM and the application over a CAN bus. The security and detection of attacks on the CAN bus is considered primarily as a responsibility of the OEM. It is mainly the diagnostic functionality that may cause problems for cyber security, since external entities need to communicate with the FCM. The preferred way to handle security is to only connect to the application system, where a secure gateway can provide connection to the necessary external services with the security implemented by the OEM. This allows each OEM to implement the cyber security procedures according to its own requirements.

Among the requirements that have relevance for the specification is that cryptographic modules shall be in line with consensus standards. Since the cryptographic methods are under constant development it should be determined what the current and future consensus standards are.

For the maritime sector DNV has published requirements in Class Guideline DNVGL-CG-0325 and requirements in Class Programme DNVGL-CP-0231. The FCM as part of the *Power generation supplying essential and important systems* is considered part of the essential and important systems and are therefore subject to risk assessment and appropriate protection against cyber-attacks. Four different security levels are defined, where level 1 only protects against casual or coincidental violations, level 2 protection against intentional violations using simple means and low resources, level 3 protection against sophisticated attacks with moderate resources and moderate motivation while level 4 protects against violations with sophisticated means, extended resources and high motivation. The risk assessment shall define which level is appropriate for the FCM, in general it can be expected that level 2 or level 3 are suitable.

The Class Programme DNVGL-CP-0231 is aligned with ISA/IEC 62443. It is a possibility to get type approval for a component, such as an FCM, which simplifies the process of integrating it into a ship. However, this requires that software versions are evaluated and approved by DNV. The class program specifies the requirements on identification and authentication, use control, system integrity, data confidentiality, restricted data flow, timely response to events, resource availability and specific systems and applications.

The system integrator shall produce the cyber security design philosophy, which will determine what security measures are required on the FCM. Under the assumption that the FCM communicates to a secure gateway on the application and does not have a direct connection to external networks the application system can handle the authentication and access control and keep the FCM complexity for the security functions limited, analogous to the requirements for vehicles.

C.2.1.4 Alarms

For the maritime sector the requirements on alarms differ from the land-based applications. In DNV's RULES FOR CLASSIFICATION (part 6 – chapter 2 – section 3), for vessels with fuel cell power installations onboard there is a requirement for hardwired signals to support alarms in case of:

- Liquid inside fuel cell space
- 40% LEL (lowest explosive limit) inside fuel cell space
- Gas detection in secondary enclosure of pipes
- Loss of ventilation or loss of negative pressure in a fuel cell space
- Loss of ventilation in secondary enclosure of pipes
- Fire detection
- Emergency release button

Our assumption is that the detection of all these can be made outside of the FCM, hence this would not require additional hardwired alarms in the connector from the FCM.

The rule proposal 2021-ENG007 from Lloyds Register also requires an alarm in case of a high differential pressure at a filter that can cause a failure of the fuel cell system. In addition, the flow, temperature and pressure of the fuel and the oxidant shall be monitored. The same rule proposal also require that the alarm control and safety systems function as independently as possible from each other, and the safety related parts of the fuel cell control system shall be independent from the other control and monitoring systems or comply with safety standards. By relying on safety systems external to the FCM when possible, a higher degree of independence is achieved. However, the interface includes messages that can be used to cover these requirements in case the FCM has the corresponding sensors internally.

For other applications the requirements on alarms and warnings are less detailed, but there is a requirement for a warning in case of hydrogen concentration exceeding 3,0% volume in air within a vehicle in UN/ECE Regulation 134. It is worth noting that this differs from the 40% of LEL that is used as threshold in ships. Hence, the definitions in the specification may need to leave out specific limits and allow for different settings for FCMs that are used in different applications.

Alarms for gas leakage and temperature deviations are supported in the digital interface, in addition to the possibility to generate alarms related to other operational parameters.



Towards a standardised fuel cell module

C.3 Standards and Architecture

In this chapter the standards that are used as basis for the StasHH digital interface are listed with the selected features. For the case where multiple FCMs are used in the same application a hierarchy with primary and secondary FCMs is described. A brief review of these and additional related standards can be found in Appendix A.

C.3.1 CAN Bus

The choice of standards has been made based on their existing support for the required functionality and the expected potential to reach a large market. For the lower layers of the protocol stack CAN bus is seen as the best candidate. This is mainly due to the popularity in the automotive sector, which is a key market for FCMs. The feasibility of using CAN bus is also warranted by the fact that multiple partners are already using it for control of FCMs.

The StasHH standard does not require CAN-FD to be used, but the intention is to fully support CAN-FD as an option. With CAN-FD a higher data rate is supported, which minimizes the concerns for bottlenecks and limitations in the size of the system.

C.3.2 SAE J1939

For the higher layers SAE J1939 also has a strong position in the heavy-duty market. The standard includes a large number of signals defined for communication within a vehicle, including hybrid vehicles. In addition to a subset of the parameters defined for the Fuel Cell Systems in J1939, the StasHH standard includes some additional parameters that provide extra functionality.

C.3.3 Architecture

There are two main considerations with regards to the architecture, how to connect multiple FCMs to an application ECU and inclusion of the DC/DC converter within the FCM.

C.3.3.1 Multiple FCMs

The first architectural question is how to connect multiple FCMs to the same application system. Then the power requests need to be divided over the different FCMs to implement an energy management strategy and the states for the FCMs shall be controlled accordingly. The alarms and warnings also need to be handled from all the FCMs.

If there is a single FCM on a CAN bus the system will appear as a single FCM system from the FCM point of view, but to avoid multiple CAN buses from the application ECU a first approach is to connect multiple FCMs over the same CAN bus as shown in Figure 17.

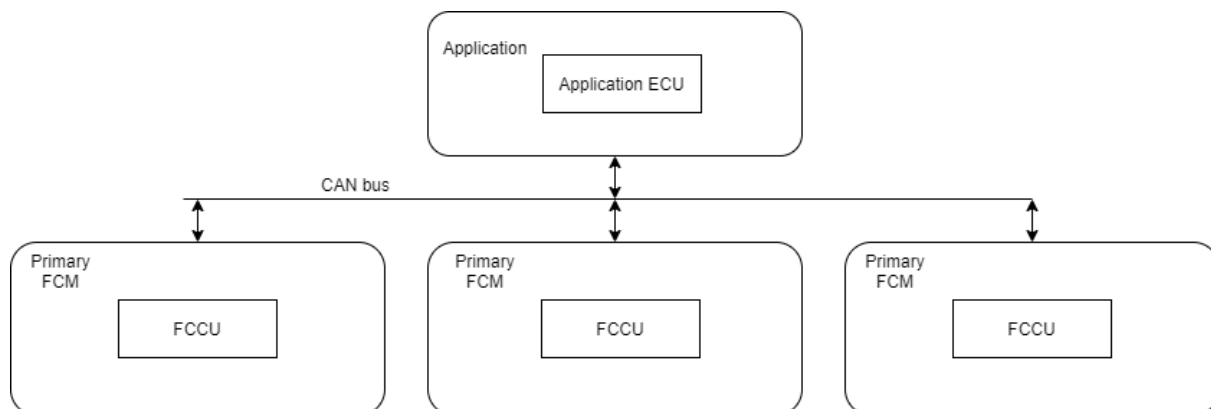

Figure 17. FCMs on a shared CAN bus.

This solution is straightforward from the FCM point of view, while the application ECU needs to handle the complexity of managing multiple FCMs. A large number of FCMs on the same CAN bus can also cause challenges with high load on the bus, in particular if the same CAN bus is used for other components, e.g. the battery or the fuel tank. For each FCM on the bus the load is in the order of 50 kb/s, with most of the data coming from mandatory signals and only a few kb/s is expected to be added by alarms and optional signals. For each of the FCMs an address shall be provided. Address 97 is assigned to the FCM controller in the J1939 address allocation and should be used when there is a single FCM. For additional FCMs, addresses from the dynamic allocation range can be used. For on-highway equipment the range of addresses for dynamic assignment contains 28 addresses (from 128 to 155). If there are not too many other devices connected to the CAN bus this leaves room for several FCMs.

To reduce the complexity of the application ECU it is often preferred to have one of the FCMs serving as a gateway that manages the other FCMs. The StasHH interface supports a topology where one FCM serves as a primary FCM that connects to the application ECU and manages other secondary FCMs, as illustrated in Figure 18. In this case the primary FCM should be assigned the source address 97.

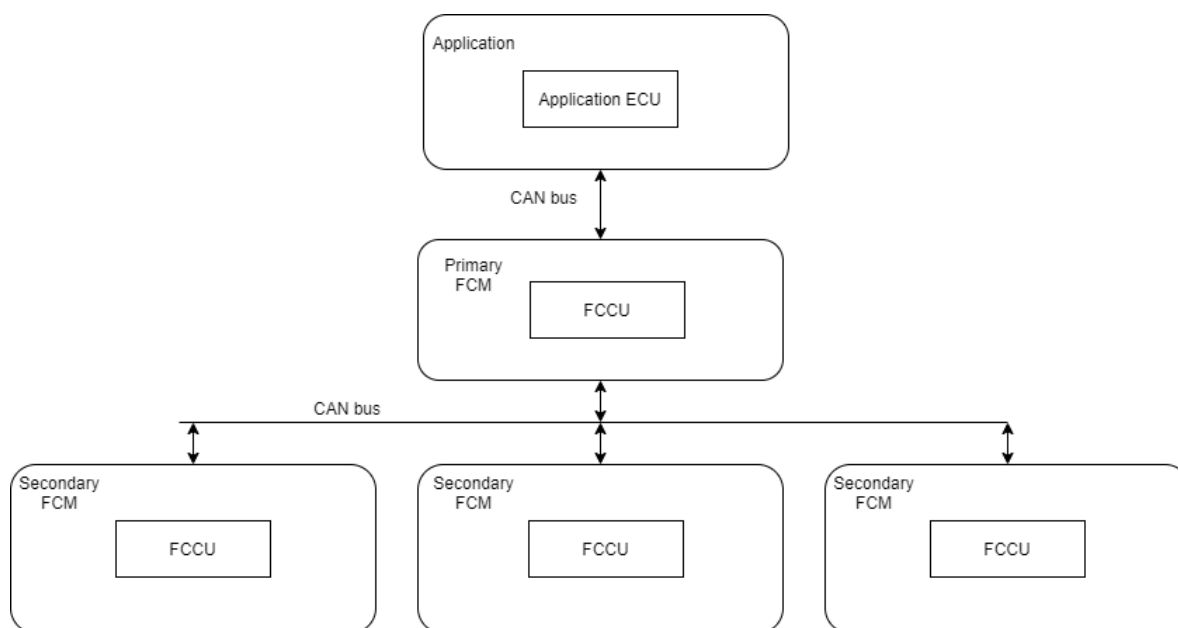

Figure 18 Primary - secondary configuration of FCMs.

The approach is to use the same StasHH standard for the interface between the application ECU and the primary FCCU as between the primary and the secondary FCCUs. The primary FCM is then responsible for providing setpoints to the different secondary FCMs to share the load according to some strategy. The load on the CAN bus between the application ECU and the primary FCCU is limited, and the CAN bus can be used also for other devices. On the CAN bus between the primary and the secondary FCMs the busload increases by approximately 50 kb/s for each secondary FCMs. The implementation of the control functionality in the primary FCM is not specified in this standard. It is not expected that the secondary CAN bus will be used for other devices than the FCMs. The full dynamic address range is therefore available for the FCMs, and there should not be any problem of increasing the number of secondary FCMs.

In principle it is possible to use the same CAN bus between the application ECU and the primary FCCU, and between the primary and secondary FCCUs. However, in this case all the messages to the secondary FCCUs would be sent first to the primary FCCU which acts as a gateway and then from the primary to the secondary FCCU. It is therefore not recommended since the bus load would be high. The connector has the option to include both the primary CAN bus and the secondary CAN bus, which makes it possible to connect the primary and secondary FCMs with daisy chain cabling.

C.3.3.2 System Boundary

First the system boundary of the FCM needs to be defined. In many applications it is preferred to have the DC/DC converter included in the FCM, while in some applications it is preferred to have an external DC/DC converter. In the first case the DC/DC converter will be controlled by the FCCU, and there is limited impact on the digital interface. In case of an external DC/DC converter, the DC/DC needs to be controlled both in terms of the basic operations, such as power limits, management of states and alarms, and in terms of providing an updated setpoint in order to draw the right amount of current from the FCM.

From the perspective of the digital interface the DC/DC converter is considered as part of the FCM, as illustrated in Figure 19. This does not require that the DC/DC is physically integrated into the FCM, but in case it is not integrated the FCM will be able to control the DC/DC.

The interface between the FCM and the external DC/DC ECU will be the same as between the application ECU and FCCU. Hence, the external DC/DC converters that will be used in this configuration will need to support the standard specified in this document. This means that it will be modelled as a generator/motor set rather than a DC/DC converter. Although there are parameter groups defined in J1939 for DC/DC converter, they lack the possibility to set a current setpoint. When the DC/DC is drawing current from the FCM a current setpoint is necessary, therefore the Fuel Cell System parameters are the preferred alternative.

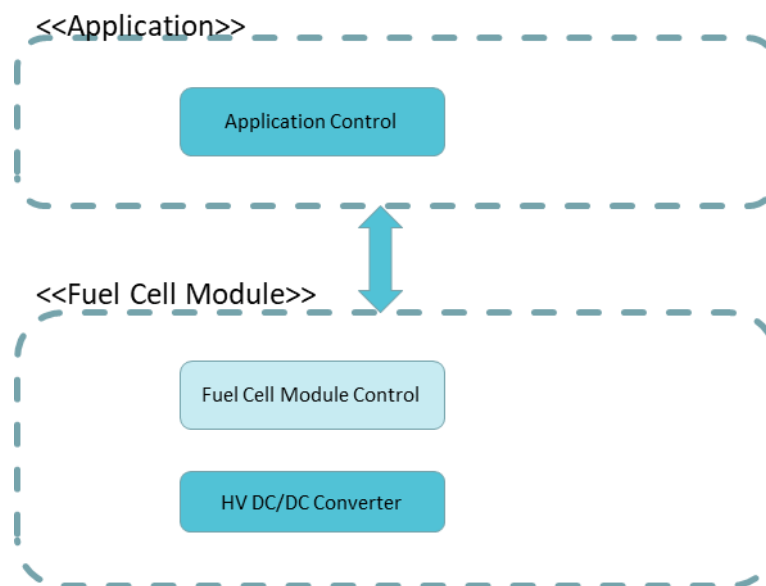

Figure 19. The FCM includes the DC/DC converter from a logical perspective.

C.4 Diagnostics and Prognostics

This section gives an overview over diagnostic and prognostic concepts and functions. As a general principle, the application system will serve as an intermediary for the collection of data for offline diagnostic and prognostic functions. Hence, all the information that is provided from the FCM to the application ECU is in principle possible for the application system to provide to cloud based diagnostic and prognostic functions.

C.4.1 Alarms and Warnings

The basic diagnostics provided through alarms and warnings are aligned with the principles used in J1939 Diagnostic Message 1 (DM1). This enables a smooth integration with automotive systems and is a proven solution that can be reused.

The principle of DM1 is that when there is any active alarm an active trouble code for that alarm will be included in the DM1 message. The Diagnostic Trouble Code (DTC) contains an identifier of the failure mode, a 5 bit field, i.e. 32 different failure modes. The SPN is used as the mechanism to identify the object of the fault. To make the solution easily portable this mechanism is proposed to be used in the standard also in case it is implemented over e.g. Ethernet instead of CAN bus.

C.4.2 Data Collection During Operations

For diagnostic and prognostic procedures where additional operation information shall be collected the cybersecurity can be a challenge. To minimize the new attack surface introduced by the FCM the information will be provided through the application system.

Although there are many possibilities to collect data and implement diagnostic procedures, the need for standardized procedures and information is more limited due to the dependence on the internal implementation of the FCM. The standard is limited to a few parameters that have been identified as the most useful.

C.4.3 Unified Diagnostic Services

For service in workshops and for on-demand control of diagnostic information the UDS protocol is used. The FCCU should support a subset of the possible services that are available in UDS, as listed in Table 9 and described here.

UDS should be used for reading and clearing stored diagnostic fault codes. This should be a complement to J1939 DM1, by allowing stored DTCs to be collected. The DTCs to be used are defined by the respective FCM manufacturers. It is recommended to use the DM1 DTCs in the DM1 format. An alternative is to have a mapping between the J1939 DTCs and the DTCs used in UDS.

Data transmission read service should be supported to read serial number and software version.

Request Download and Transfer data services should be supported for updating of SW. In addition, the control DTC setting should be supported to disable error detection during SW updates.

Remote Activation of Routine may be supported for starting and stopping of diagnostic controls or service procedures.

Security is supported either with security access or with authentication. The diagnostic session control shall also be supported as a part of the security solution. It is recommended to use appropriate security

levels for the application with separation of security levels for roles and use cases. Due to the differences in use cases, with possible implementation of UDS clients in workshops and vehicle gateways, as well as applications that may not have connection to the Internet both the requirements and the practical limitations imply that there is no single solution that fits all use cases. Hence, it is left to the OEM to define the security strategy and the FCM implementation needs to support the required functionality.

Table 9. UDS services supported by the StasHH standard.

Service	Request SID	Response SID	Comment
Diagnostic Session Control	0x10	0x50	
Security Access	0x27	0x67	Symmetric cryptography
Authentication	0x29	0x69	With asymmetric encryption
Control DTC Setting	0x85	0xC5	To disable error detection, e.g. during SW updates.
Read DTC information	0x19	0x59	
Clear DTCs	0x14	0x54	
Read data by ID	0x22	0x62	DID = 0xF180 SW identification DID = 0xF18C serial number
Write data by ID	0x2E	0x6E	
Request Download	0x34	0x74	
Transfer Data	0x36	0x76	
Request Transfer Exit	0x37	0x67	
Routine control	0x31	0x71	For activation of test procedures

C.5 Interface Specification

In the following specification we will refer to VCU and application ECU interchangeably, although the controlling ECU may be called something else than VCU in some applications. The chapter contains an overview to put the protocol into context, a description of the state machine, specification of the signals and usage examples.

C.5.1 Communication Procedure Approach

The main task of the FCM is to supply the power requested by the VCU. The VCU will execute an energy management strategy for the operation of the HV battery and the FCM.

The main idea behind the following required signals is given by an example of a simplified powertrain strategy for an electric road vehicle:

First, the driver requests torque for constant driving or acceleration by controlling the acceleration pedal. The VCU calculates the required power demand for the E-drive. Based on actual state of charge of the HV battery, the operation state of the FCM and other environmental conditions, the energy management will split the power demand between battery and FCS. The VCU will send a power request to the FCM and send a power setpoint to the electric-drive system, the power gap is covered by the HV battery. For immediate torque, first the power will be provided by the HV battery, until the FCM power output has ramped up to supply it and even charge the battery.

$$\text{Power_HV_Battery} = \text{Power_E-drive} - \text{Power_FCM}$$

<p>Example 1:</p> <p>Power_E-drive = 100kW</p> <p>Power_FCM = 70kW</p> <p>-> Power_HV_Battery = 30kW -> HV battery is discharging</p>	<p>Example 2:</p> <p>Power_E-drive = 50kW</p> <p>Power_FCM = 70kW</p> <p>-> Power_HV_Battery = -20kW -> HV battery is charging</p>
---	--

The VCU is aware of the amount and the status of the connected FCMs by evaluation of the alive counters and by monitoring the state feedback and diagnostic signals from the primary FCCU.

If power for the E-drive is required, the VCU's energy management or the primary FCCU has to decide to e.g. run one system at full load, or split it between 2 FCMs at half load. Therefore, the state requests are required to start the FCMs.

C.5.2 State Machine

A state machine for the main states of the FCM is shown in Figure 20. It should be possible for a FCM manufacturer to define proprietary substates to these main states. It may be noted that some substates are defined in the J1939 Fuel Cell System State Machine, for example a low voltage standby and a high voltage standby state, as well as multiple states during the stopping state. The properties of the different states are described in this section.



Towards a standardised fuel cell module

C.5.2.1 Idle

In the Idle state the FCM has LV voltage power such that the FCCU is active. This state corresponds to the "System self-check" state in J1939. However, the FCM may remain in this state after self-check, e.g. to maintain a low energy consumption.

Periodic counter messages are transmitted.

C.5.2.2 Standby

In the standby state the FCM does not output power on the HV interface yet but the necessary subsystems are powered and ready such that it can start producing output within a short time. The HV bus may or may not be connected to the FCM.

Error and diagnostic messages can be sent.

C.5.2.3 Starting

The FCM is transitioning from the standby state to the running state. During this state the delivered power is ramping up, and therefore the power level is not well-defined. The HV bus is enabled and the module can consume and provide energy.

C.5.2.4 Running

The FCM is active and delivering power.

The power may be limited due to derating which will be indicated by the FCM.

C.5.2.5 Stopping

The FCM is ramping down power delivery and returning to standby state, idle state or possibly to power off state in case of emergency shut down.

The HV bus must be enabled during shut-down routines. The output power is not well-defined.

C.5.2.6 Error

The error state can be entered from any other state.

The FCM should be brought to a safe state.

In comparison with the FCS state machine defined in J1939, the StasHH state machine defines an expected behavior for the post shutdown procedure, such that the application ECU can control which state the FCM ends up in after a stop request.

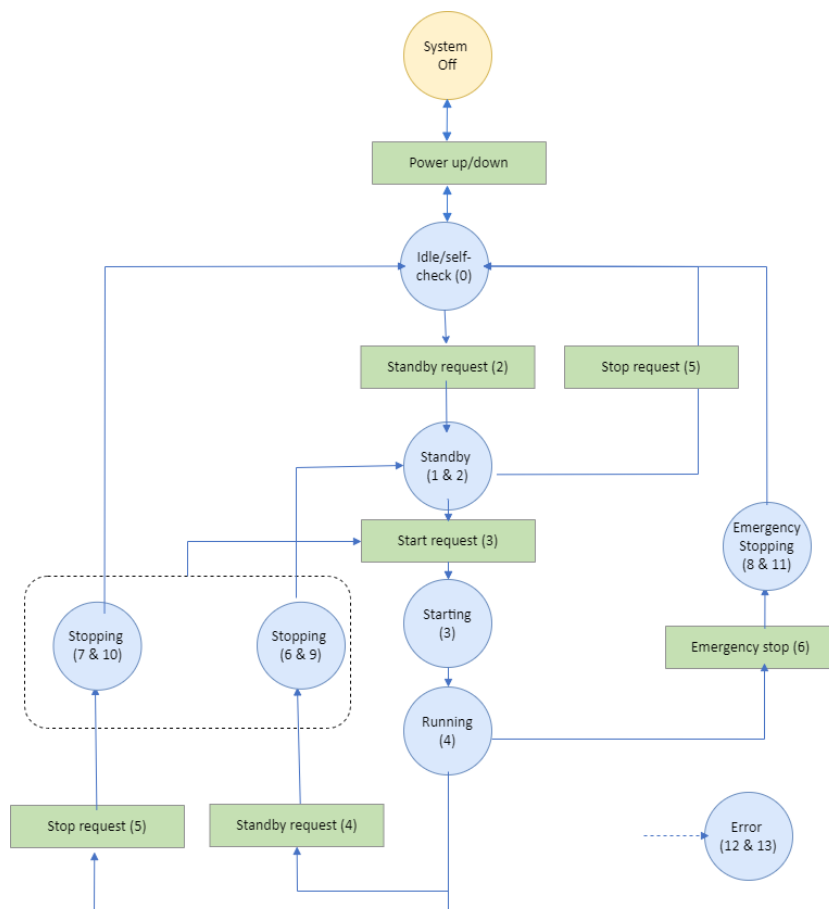

Figure 20. State machine of the FCM. The numbers refer to the values used in the request and state feedback messages.

C.5.3 Messages

This section lists the messages that are used in the communication between the application ECU and the FCCU, both with a generic description and a mapping to a J1939 message. Note that the signal layouts are intended to follow J1939, the details can be found in the accompanying DBC. The version of J1939 used for the standard is the June 2024¹ edition.

In general, the reliability of the communication will be protected with message sequence numbers and cyclic redundancy check (CRC) codes. The primary FCM should use the source address 97, which is defined as the Fuel Cell System source address. Following the J1939 specification, little endian shall be used.

C.5.3.1 State Machine Control

Direction: From VCU to FCCU

The state of the FCM is controlled by requests from the application ECU. The specification gives a basis with main operation states but depending on the FCM there may be further substates than the main

¹ In the first version the March 2021 edition was used. This version is using Fuel Cell System PGs that are added in 2024.

states in Figure 20. Additional substates will make it possible to support more specific energy management strategies, for example to handle cold starts.

An FCM state request message will be sent from the application ECU to the FCCU with a request for a new state. The possible state parameters are the ones indicated from the state machine:

- Self-check command
 - The VCU may send the self-check command to trigger the self-check procedure while in idle state.
- Standby request
 - The standby state can be entered from the idle state using the standby command. The request does not require any additional parameters for mode or setpoint.
- Start request
 - The start request will change the state to running via the starting state. The FCM needs to have a setpoint for the power or current. The request shall indicate whether power or current setpoint is used.
- Stop request
 - The stop request (medium priority shutdown) will change the state to idle. If the initial state is standby the FCM can transition directly to the idle state. If the stop request is received in the running state, the FCM will transition to idle via the stopping state.
- Low priority stop
 - The low priority stop will change the state from running to standby, via the stopping state.
 -
- Emergency stop
 - Command to shut down this FCM, which will transition the FCM to the idle state. A normal power-down may involve steps that take some time (tests, writing of data, etc.). However, an emergency power-down should shut down the FCM as quickly as possible, for example in the event of a vehicle accident. The FCM should always support the command to execute emergency power-down, even if the actual power-down process is the same as that used during a "normal" power-down.

Note that the transition from the idle state to a completely off state has to be made by other means than this protocol, e.g. switching off the LV power to the FCM, or using a proprietary request.

In addition, the control mode will be selected, either the power control mode or the current control mode can be used.

The message will contain the requested setpoint for the net output power or current delivery in addition when the running state has been requested.

There is also the possibility to command the FCM to purge water from the system either immediately or at the next shutdown.

Mapping to SAE J1939

The state request message is implemented using the Fuel Cell System Control Command parameter group in J1939. Further details of the signal definition may be found in the J1939 Digital Annex². The cycle time of the message is 10 ms with priority 3.

Table 10. Parameter group Fuel Cell System Control Command.

PGN	PG label	SPN	SP label	Scaling	Range	Length	Startbit
15872	FCSCC	23147	CRC	1 count per bit	0 to 255 count	1 byte	0
15872	FCSCC	23148	Counter	16 states	0 to 15	4 bits	8
15872	FCSCC	23149	State Command	16 states	0 to 15	4 bits	16
15872	FCSCC	23150	Mode Command	16 states	0 to 15	4 bits	20
15872	FCSCC	23151	Net Output Command	0.003 906 25 % per bit	-125 to 125.996 093 75 %	2 bytes	24
15872	FCSCC	23152	Fuel Cell System Purge Water Command	8 states	0 to 7	3 bits	40

Description of the parameters used in the standard:

CRC – SPN 23147: 8 bit CRC calculated over the data, source address and PGN. The definition from SAE J1939 is used.³

Counter – SPN 23148: 4 bit counter that counts from 0 to 15 and then restarts. This is used for detection of repeated frames.

State Command – SPN 23149: 4 bits field that requests the FCM to enter specific states. The standard state requests supported in this standard are:

No command: Value = 0

Power on request: Value = 1 – FCS perform self-check command

Standby request: Value = 2 – FCS standby command

Start request: Value = 3 – FCS active command

Low priority stop request: Value = 4 - FCS low priority shutdown command to transition to standby state

Stop request: Value = 5 – FCS medium priority shutdown command to transition to idle state.

Emergency stop: Value = 6 - FCS high priority shutdown command.

² The SAE J1939 Digital Annex from March 2021 has been used for the parameters in this standard. Additional details may be found in J1939/21, J1939/71 and J1939/73.

³ The CRC is defined as follows: Length: 8 bits; Polynomial: $x^8+x^5+x^3+x^2+x+1$; Initial Value: FFh; Input Data Reflection: Not reflected; Result Data Reflection: Not reflected; XOR value: FFh.

Mode request – SPN 23150: 4 bits field that specifies the control mode, the

- Value = 1 - Enable DC Power Control Mode - In this mode Control Setpoint Request is the DC Side Power Setpoint in %. Refer to SPN 23144 [Reference Power] to convert % to kW.
- Value = 2 - Enable DC Side Current Control Mode (w/o DC/DC) – In this mode Control Setpoint Request is the DC Side Current Setpoint in %. Refer to SPN 23145 [Reference Current] to convert % to A.

Net Output Command – SPN 23151

- in % of reference value, with the mode selected in SPN 23151, i.e. the reference will either be in kW (mode 1) or Ampere (mode 2).

Purge Water Command – SPN 23152, this is an optional signal that may be used to command the FCM to purge excess water. Values used:

- 0 = Water is not commanded to be purged from the fuel cell stacks
- 1 = Water is commanded to be purged from the fuel cell stacks at the next shutdown
- 2 = Water is commanded to be purged from the fuel cell stacks immediately

C.5.3.2 State Machine Feedback

Direction: From FCCU to VCU

The FCCU reports the current state to the application ECU using this message. In addition to the state of the FCM the state of the HVIL is essential for the operation of the FCM since it is necessary to have the HV connected in the standby and running states. Therefore, the HVIL status is also included in the state feedback.

The information included in the message are the FCM state and the HVIL status. In case HVIL is not used the FCM can signal "N/A".

There is also a possibility to indicate that the FCM is in cold start, which will increase the time before the full net output power can be provided.

Table 11. Fuel Cell System Operating State (FCSOS), the grey elements are part of the reused J1939 PG but are not used in the FCM standard.

PGN	PG label	SPN	SP label	Scaling	Range	Length	Startbit
62327	FCSOS	23192	CRC	1 count per bit	0 to 255 count	1 byte	0
62327	FCSOS	23193	Counter	16 states	0 to 15	4 bits	8
62327	FCSOS	23194	Cold Start Active Status	4 states	0 to 3	2 bits	16
62327	FCSOS	23195	Control Mode	16 states	0 to 15	4 bits	18
62327	FCSOS	23196	Operation State	256 states	0 to 255	8 bits	24
62327	FCSOS	23197	Fault Level	8 states	0 to 7	3 bits	32
62327	FCSOS	23734	FCS HVIL status	4 states	0 to 3	2 bits	35



Towards a standardised fuel cell module

Mapping to SAE J1939

The state feedback is signalled using the Fuel Cell System Operating State (FCSOS) which is aligned with the mode used for the control of the FCM. The cycle time of the message is 100 ms, the priority is 6.

Cold start active – SPN 23194, 2 bits used to indicate whether the FCM is in cold start state, values:

00b = Cold start not active

01b = Cold start active

11b = Not available

FCM control mode – SPN 23195, 4 bits used to indicate the control mode that has been set, values:

0 = No control mode requested

1 = Power control mode

2 = Current control mode

FCM states – SPN 23196. 8 bits to indicate the state of the FCM, values that are being used:

0 = Idle / system self-check state - the inverter is commanded to be powered on and able to communicate, but the Power Stage is disabled e.g. no switching or output.

1 = Standby – the FCM is in a neutral operating mode without being connected to the HV bus.

2 = Standby - the FCM is powered and commanded to a neutral operating mode while being connected to the HV bus.

3 = Starting state, the FCM is starting to deliver power on the HV bus.

4 = Operating state.

6, 7, 8, 9, 10, 11 = Stopping state. The different states can be used based on the different stop requests as defined in the J1939DA. These are considered as substates of the StasHH stopping state.

12/13 = Error state. The substate 12 is expected to be a transition state that brings the FCM to a safe state, i.e. substate 13.

SPN 23734 – Inverter HVIL status

Reports the High Voltage Interlock Loop (HVIL) state.

00b = HVIL Closed

01b = HVIL Open

10b = Error

11b = Not Available

C.5.3.3 Reference Power Value

Direction: From FCCU to VCU

The setpoints for the power, voltage or current from VCU to FCCU are provided using percentage values relative to a reference. The reference values are provided by the FCCU to the application ECU in kW, Volt or Ampere. The FCM shall provide updated reference values according to the state of health and operating condition.

These values can also be used as set point values for the external DC/DC converter. As source/destination addresses differ, also sharing the same CAN bus is possible. Depending on the DC/DC operational mode, there will be a current set point (galvanostatic control) or a voltage setpoint (potentiostatic control).

Mapping to SAE J1939

Fuel Cell System Configuration, PGN 63999, is used to provide the reference values for power, current and voltage.

The transmission interval is five seconds for the parameter group, and the priority level is 6.

Table 12. Fuel Cell System Configuration.

PGN	PG label	SPN	SP label	Scaling	Range	Length	Startbit
63999	FCSC	23142	CRC	1 count per bit	0 to 255 count	1 byte	0
63999	FCSC	23143	Counter	16 states	0 to 15	4 bits	8
63999	FCSC	23144	FCS Reference Power	0.05 kW per bit	0 to 3 212.75 kW	2 bytes	16
63999	FCSC	23145	FCS Reference Current	0.05 A per bit	0 to 3 212.75 A	2 bytes	32
63999	FCSC	23146	FCS Reference Voltage	0.05 V per bit	0 to 3 212.75 V	2 bytes	48

The parameters that are used in the standard are as follows.

Reference Power – SPN 23144

The granularity is 0.05 kW, with a 16 bit length of the reference power that results in a range from 0 to 3212.75 kW.

Reference Current – SPN 23145

The granularity is 0.05 A per bit, with a 16 bit length of the reference power that results in a range from 0 to 3212.75 A.

Reference Voltage – SPN 23146

The granularity is 0.05 V per bit, with a 16 bit length of the reference power that results in a range from 0 to 3212.75V.

C.5.3.4 FCM Actual Current and Voltage

Direction: From FCCU to VCU

The FCM status informs the application ECU about the actual voltage and current delivery from the FCM. The values are from the output (HV side) of the DC/DC converter. The values are sent as percentages of the reference values, which is aligned with how the setpoints are sent from the application ECU.

If the FCM does not have an integrated DC/DC the value is from the output of the DC/DC converter.

Mapping to SAE J1939

The FCM status is sent using the Fuel Cell System Controller Information parameter group, PGN 62321. The transmission interval is 10 ms, with priority 3.

Table 13. Fuel Cell System Controller Information

PGN	PG label	SPN	SP label	Scaling	Range	Length	Startbit
62321	FCSCI	23153	CRC	1 count per bit	0 to 255 count	1 byte	0
62321	FCSCI	23154	Counter	16 states	0 to 15	4 bits	8
62321	FCSCI	23155	Fuel Cell System Net Power	0.003 906 25 % per bit	-125 to 125.996 093 75 %	2 bytes	16
62321	FCSCI	23156	Fuel Cell System Net Current	0.003 906 25 % per bit	-125 to 125.996 093 75 %	2 bytes	32
62321	FCSCI	23157	Fuel Cell System Voltage	0.003 906 25 % per bit	-125 to 125.996 093 75 %	2 bytes	48

The torque and speed status are not used, only the current and voltage parameters.

Net Power – SPN 23155. The actual net power output of the fuel cell module, expressed as a percentage of the reference power in SPN 23144.

Current Value – SPN 23156. The actual current output from the high voltage side of the DC/DC converter, as a percentage of the reference value in SPN 23145. The current may be negative if the balance of plant is drawing energy from the high voltage bus.

Voltage Value – SPN 23157. The actual voltage for the high voltage side of the DC/DC converter, as a percentage of the reference value in SPN 23146.

C.5.3.5 Power Limits

Direction: From FCCU to VCU

The maximum and minimum power that can be delivered by the FCM within the next defined period of time. E.g. in the next one second the FCM can output a certain minimum or maximum power. The application ECU can use this information to calculate the power available from FCM. The minimum is the power delivered during FCM idling. A lower power output could cause high stack cell voltage that may harm the fuel cell stack.

Mapping to SAE J1939

The message is implemented using the Fuel Cell System Minimum Power Information and Fuel Cell System Maximum Power Information in J1939, which provides the minimum and maximum limits for the electrical power.

The transmission interval is 100ms and on change of the value of more than 10%, but not faster than 10ms. The priority level is 3.

Table 14. Fuel Cell System Minimum Power Information. Grey elements are part of the reused J1939 PG but are not used.

PGN	PG label	SPN	SP label	Scaling	Range	Length	Startbit
62322	FCSMNPI	23162	CRC	1 count per bit	0 to 255 count	1 byte	0
62322	FCSMNPI	23163	Counter	16 states	0 to 15	4 bits	8
62322	FCSMNPI	23164	Fuel Cell System Actual Minimum Available Net Power	0.003 906 25 % per bit	-125 to 125.996 093 75 %	2 bytes	16
62322	FCSMNPI	23165	Fuel Cell System Internal Minimum Available Net Power	0.003 906 25 % per bit	-125 to 125.996 093 75 %	2 bytes	32
62322	FCSMNPI	23166	Fuel Cell System Actual Minimum Available Net Power Source Address	1 source address per bit	0 to 255 source address	1 byte	48

Table 15. Fuel Cell System Maximum Power Information. Grey elements are part of the reused J1939 PG but are not used.

PGN	PG label	SPN	SP label	Scaling	Range	Length	Startbit
62323	FCSMXPI	23167	CRC	1 count per bit	0 to 255 count	1 byte	0
62323	FCSMXPI	23168	Counter	16 states	0 to 15	4 bits	8
62323	FCSMXPI	23169	Fuel Cell System Actual Maximum Available Net Power	0.003 906 25 % per bit	-125 to 125.996 093 75 %	2 bytes	16
62323	FCSMXPI	23170	Fuel Cell System Internal Maximum Available Net Power	0.003 906 25 % per bit	-125 to 125.996 093 75 %	2 bytes	32
62323	FCSMXPI	23171	Fuel Cell System Actual Maximum Available Net Power Source Address	1 source address per bit	0 to 255 source address	1 byte	48

The SPNs that are used in the standard are:

Min Power– SPN 23165. Minimum value that the FCM can deliver, signaled as a percentage of the reference power in SPN 23144.

Max Power– SPN 23170. The value is the predicted maximum that the FCM will keep the power below. It is signaled as a percentage of the reference power in SPN 23144.

C.5.3.6 Voltage Limits

Direction: From VCU to FCCU.

The FCM can provide recommended maximum and minimum limits on the operating voltage. These limits can be used to prevent operating conditions that can damage the battery. These values shall not change during operation and are therefore only transmitted when requested by the FCCU. The voltage value refers to the high voltage side of the DC/DC converter, also in case the DC/DC is physically external to the FCM.

Mapping to SAE J1939

The J1939 parameter group used to implement the message is Fuel Cell System Voltage Limit Command, PGN 63936. These values are provided as a percentage of the reference voltage for the fuel cell system. The parameter group is sent on request, with priority level 6.

Table 16. Fuel Cell System Voltage Limit Command.

PGN	PG label	SPN	SP label	Scaling	Range	Length	Startbit
63936	FCSVLC	23729	FCSVLC CRC	1 count per bit	0 to 255 count	1 byte	0
63936	FCSVLC	23730	FCSVLC Counter	16 states	0 to 15	4 bits	8
63936	FCSVLC	23731	Nominal Voltage	0.003 906 25 % per bit	-125 to 125.996 093 75 %	2 bytes	16
63936	FCSVLC	23732	Minimum Operating Voltage	0.003 906 25 % per bit	-125 to 125.996 093 75 %	2 bytes	32
63936	FCSVLC	23733	Maximum Operating Voltage	0.003 906 25 % per bit	-125 to 125.996 093 75 %	2 bytes	48

The SPNs that are used in the standard are:

Fuel Cell System Nominal Voltage Command– SPN 23731. The scaling is 0.003 906 25 % per bit, as a percentage of the reference voltage in SPN 23146.

Fuel Cell System Minimum Operating Voltage Command- SPN 23732. The scaling is 0.003 906 25 % per bit, as a percentage of the reference voltage in SPN 23146.

Fuel Cell System Maximum Operating Voltage Command - SPN 23733. The scaling is 0.003 906 25 % per bit, as a percentage of the reference voltage in SPN 23146.

C.5.3.7 High Voltage Bus Information

Direction: From VCU to FCCU

This message indicates to the FCM whether the HV bus is available. The system cannot be started if the HV bus is not available, as the HV bus needs to draw power from the FCM and components connected to the HV system are not supplied with power, e.g. the coolant pump and compressor. The status can be one of the following states:

- | | |
|----------------------------|-------------------------------|
| 0: Not connected. | 3: Disconnection in progress. |
| 1: Connected. | 5: Disconnection is imminent. |
| 2: Connection in progress. | 14: Error. |



Mapping to J1939

The message is implemented using the High Voltage Bus Information, PGN 64363 in J1939. The message is sent at every second or event-triggered when the status is changed. However, the minimum interval between transmissions is 100 ms in case of frequent changes of the status. The priority level is 6.

Table 17. High Voltage Bus Information. Grey elements are part of the reused J1939 PG but are not used.

PGN	PG label	SPN	SP label	Scaling	Range	Length	Startbit
64363	HVBI	10298	High Voltage DC Bus Availability	16 states	0 to 15	4 bits	0
64363	HVBI	20802	High Voltage Bus Driveline Availability	16 states	0 to 15	4 bits	4
64363	HVBI	20803	High Voltage Bus Auxiliaries Availability	16 states	0 to 15	4 bits	8
64363	HVBI	20804	High Voltage Bus ePTO Availability	16 states	0 to 15	4 bits	12
64363	HVBI	20805	High Voltage Bus On-Board Charger Availability	16 states	0 to 15	4 bits	16
64363	HVBI	20806	High Voltage Bus Off-Board Charger Availability	16 states	0 to 15	4 bits	20

The parameter that shall be used to indicate the connection of the HV DC bus is Driveline Availability – SPN20820 for HV Connection Status. The values are:

0000b = High voltage DC bus is not connected.

0001b = High voltage DC bus is connected.

0010b = High voltage DC bus connection is in process of being connected.

0011b = High voltage DC bus disconnection is in process. Devices on the bus should take appropriate action.

0101b = High voltage DC bus disconnect forewarning. Disconnection is imminent.

1110b = Error

1111b = Not Available

The rest of the values are SAE reserved.

C.5.3.8 FCM Temperature

Direction: From FCCU to VCU

This is an optional message.

This message is used to provide feedback about the FCM temperature for FCMs with multiple sensors. It can also provide a setpoint for the temperature of the coolant that an external cooling system shall aim for. This message can for example be used to report the temperature of the coolant at the intake and the outlet. If location of the temperature sensors differ from this, it should be documented by the manufacturer.

Mapping to J1939

The FCM temperature message is mapped to the Fuel Cell System Coolant Information 1, PGN 64000 in J1939. The message transmission interval is one second and the priority level is 6.

Table 18. Fuel Cell System Coolant Information 1.

PGN	PG label	SPN	SP label	Scaling	Range	Length	Startbit
64000	FCSCI1	23201	Fuel Cell System Coolant Inlet Temperature Setpoint	0.031 25 °C per bit	-273 to 1734.968 75 °C	2 bytes	0
64000	FCSCI1	23202	Fuel Cell System Coolant Inlet Temperature	0.031 25 °C per bit	-273 to 1734.968 75 °C	2 bytes	16
64000	FCSCI1	23203	Fuel Cell Stack Coolant Inlet Temperature	1 °C per bit	-40 to 210 °C	1 byte	32
64000	FCSCI1	23204	Fuel Cell Stack Coolant Outlet Temperature	1 °C per bit	-40 to 210 °C	1 byte	40

The FCM may use as many of the parameters as needed for the sensor in the FCM. The two first parameters are using two bytes each and have a range up to 1735 degree Celsius, while the last two are single byte and have a range up to 210 degrees.

C.5.3.9 Air Filter Pressure

Direction: from FCCU to VCU

This is an optional message.

If the FCM has sensors on the air filter the differential pressure between the sides of the filter can be an indication of accumulating of particles in the filter and therefore give an indication on when it is time to replace the filter. It may also be required to fulfil safety requirements in some maritime applications.

Mapping to J1939

The message is mapped to the parameter group Intake/Exhaust Conditions 2, PGN 64976. This PG is sent every 500 ms with priority 6.

Table 19. Intake/Exhaust Conditions 2

PGN	PG label	SPN	SP label	Scaling	Range	Length	Startbit
64976	IC2	2809	Engine Air Filter 2 Differential Pressure	0.05 kPa per bit	0 to 12.5 kPa	1 byte	0
64976	IC2	2810	Engine Air Filter 3 Differential Pressure	0.05 kPa per bit	0 to 12.5 kPa	1 byte	8
64976	IC2	2811	Engine Air Filter 4 Differential Pressure	0.05 kPa per bit	0 to 12.5 kPa	1 byte	16
64976	IC2	3562	Engine Intake Manifold #2 Pressure	2 kPa per bit	0 to 500 kPa	1 byte	24
64976	IC2	3563	Engine Intake Manifold #1 Absolute Pressure	2 kPa per bit	0 to 500 kPa	1 byte	32
64976	IC2	4817	Engine Intake Manifold 1 Absolute Pressure (High Resolution)	0.1 kPa per bit	0 to 6 425.5 kPa	2 bytes	40
64976	IC2	5422	Engine Intake Manifold 2 Absolute Pressure	2 kPa per bit	0 to 500 kPa	1 byte	56

The parameter that is used in the standard is the Air Filter 2 Differential Pressure - SPN 2809.

C.5.3.10 Fuel Information

Direction: from FCCU to VCU

This is an optional message.

The fuel information is used for the FCM to provide an estimate of the fuel consumption measured in kg/h. This can be used together with the power output for the application ECU to calculate the estimated fuel efficiency. The information may also be needed to fulfil the safety requirements in some maritime applications. There is no requirement specified on the accuracy of the estimate, hence it is not required to use a flow meter but the FCM can provide an estimate according to its own implementation.

Mapping to J1939

The message is mapped to Fuel Information 3 (Gaseous), PGN 64930. The PG is sent every 500 ms with priority level 4.

Table 20. Fuel Information 3 (Gaseous).

PGN	PG label	SPN	SP label	Scaling	Range	Length	Startbit
64930	GFI3	3466	Engine Fuel Valve 2 Intake Absolute Pressure	0.1 kPa per bit	0 to 6 425.5 kPa	2 bytes	0
64930	GFI3	3467	Engine Fuel System 2 Gas Mass Flow Rate	0.05 kg/h per bit	0 to 3 212.75 kg/h	2 bytes	16
64930	GFI3	3468	Engine Fuel 1 Temperature 2	1 °C per bit	-40 to 210 °C	1 byte	32
64930	GFI3	3469	Engine Fuel Valve 2 Outlet Absolute Pressure	0.1 kPa per bit	0 to 6 425.5 kPa	2 bytes	48

The standard includes the gas mass flow rate, SPN 3467, measured in kg/h.

C.5.3.11 FCM Operating Hours

Direction: From FCCU to VCU

This is an optional message. The FCM can report the accumulated hours of operation, which can be used in diagnostic and prognostic functions.

Mapping to J1939

The accumulate operating time is implemented using the engine total hours of operation parameter group in J1939. The parameter group is sent on request. The priority level is 6.

Table 21. Operating Hours of Fuel Cell Module.

PGN	PG label	SPN	SP label	Scaling	Range	Length	Startbit
65253	HOURS	247	Engine Total Hours of Operation	0.05 h per bit	0 to 210 554 060.75 h	4 bytes	0
65253	HOURS	249	Engine Total Revolutions	1 000 r per bit	0 to 4 211 081 215 000 r	4 bytes	32

Only the hours parameter, SPN 247, is used for the FCM. The step size is 0.05 h per bit, with a 4 byte data field that results in a range from 0 to 210 554 060.75 hours.

C.5.3.12 Time and Date

Direction: From VCU to FCCU.

Time and date information is provided from the vehicle to the FCCU to keep the clock synchronized. The FCCU can use the time and date for time stamping of diagnostic information.

Mapping to J1939

The message is implemented using the Time/Date PG with PGN 65254. The parameter group is sent by the application ECU only when it is requested by the FCCU. The priority level is 6.

Table 22. Time/Date parameter group.

PGN	PG label	SPN	SP label	Scaling	Range	Length	Startbit
65254	TD	959	Seconds	0.25 s per bit	0 to 62.5 s	1 byte	0
65254	TD	960	Minutes	1 min per bit	0 to 250 min	1 byte	8
65254	TD	961	Hours	1 h per bit	0 to 250 h	1 byte	16
65254	TD	963	Month	1 month per bit	0 to 250 month	1 byte	24
65254	TD	962	Day	0.25 days per bit	0 to 62.5 days	1 byte	32
65254	TD	964	Year	1 year per bit	1 985 to 2 235 year	1 byte	40
65254	TD	1601	Local minute offset	1 min per bit	-125 to 125 min	1 byte	48
65254	TD	1602	Local hour offset	1 h per bit	-125 to 125 h	1 byte	56

All parameters of the PG are used. Time is reported as UTC (Universal Time Coordinate). However, the parameters local hour offset and local minute offset can be used to report the local time.

C.5.3.13 Ambient Conditions

Direction: from VCU to FCCU

This is an optional message.

The ambient temperature can be used to adapt the startup procedure to the ambient temperature, e.g. freeze start. In addition, the barometric pressure may be used for adapting the operation to the altitude, e.g. compressor control.

Mapping to J1939

The message is mapped to Ambient Conditions, PGN 65269. This parameter group is sent once every second to the FCCU. The priority level is 6.

Table 23. Ambient Conditions parameter group. Grey elements are part of the reused J1939 PG but are not used.

PGN	PG label	SPN	SP label	Scaling	Range	Length	Startbit
65269	AMB	108	Barometric Pressure	0.5 kPa per bit	0 to 125 kPa	1 byte	0
65269	AMB	170	Cab Interior Temperature	0.031 25 °C per bit	-273 to 1734.968 75 °C	2 bytes	8
65269	AMB	171	Ambient Air Temperature	0.031 25 °C per bit	-273 to 1734.968 75 °C	2 bytes	24
65269	AMB	172	Engine Intake 1 Air Temperature	1 °C per bit	-40 to 210 °C	1 byte	40
65269	AMB	79	Road Surface Temperature	0.031 25 °C per bit	-273 to 1734.968 75 °C	2 bytes	48

The parameters used in the standard are the Barometric Absolute Pressure, SPN 108, and the ambient air temperature, SPN 171.

C.5.3.14 Vehicle Speed

Direction: from VCU to FCCU

This is an optional message.

The vehicle speed can be used as additional information in diagnostics, where different diagnostic reactions may be performed depending on the speed.

Mapping to J1939

The message is implemented using the Tachograph PG, with PGN 65132. This parameter group is sent every 50 ms with priority level 3.

Table 24. Tachograph parameter group. The grey elements are part of the reused J1939 PG but are not used in the FCM standard.

PGN	PG label	SPN	SP label	Scaling	Range	Length	Startbit
65132	TCO1	1612	Driver 1 working state	8 states	0 to 7	3 bits	0
65132	TCO1	1613	Driver 2 working state	8 states	0 to 7	3 bits	3
65132	TCO1	1611	Vehicle motion	4 states	0 to 3	2 bits	6
65132	TCO1	1617	Driver 1 Time Related States	16 states	0 to 15	4 bits	8
65132	TCO1	1615	Driver card, driver 1	4 states	0 to 3	2 bits	12
65132	TCO1	1614	Vehicle Overspeed	4 states	0 to 3	2 bits	14
65132	TCO1	1618	Driver 2 Time Related States	16 states	0 to 15	4 bits	16
65132	TCO1	1616	Driver card, driver 2	4 states	0 to 3	2 bits	20
65132	TCO1	1622	System event	4 states	0 to 3	2 bits	24
65132	TCO1	1621	Handling information	4 states	0 to 3	2 bits	26
65132	TCO1	1620	Tachograph performance	4 states	0 to 3	2 bits	28
65132	TCO1	1619	Direction indicator	4 states	0 to 3	2 bits	30
65132	TCO1	1623	Tachograph output shaft speed	0.125 rpm per bit	0 to 8031.875 rpm	2 bytes	32
65132	TCO1	1624	Tachograph vehicle speed	0.003 906 25 km/h per bit	0 to 250.996 093 75 km/h	2 bytes	48

The parameter that is relevant for the StasHH standard are the vehicle speed, SPN 1624.

C.5.3.15 FCM Hydrogen Concentration

Direction: From FCCU to VCU

This is an optional message.

Detection of hydrogen leakage may be implemented on the FCM, in addition to in the application system itself. For this reason, a message is defined which can be used by the FCM to notify the application ECU about a gas leakage. In particular, for applications where it is a safety requirement to provide an alarm in case of gas leakage this can be used to provide such an alarm. The application ECU should consider that the hydrogen concentration information is an absolute measure, hence not relative to the explosive limit of hydrogen. The message has room for measurement values from multiple sensors which may be placed at different locations.

Mapping to J1939

This message is implemented using the Fuel Cell Compartment Information, PGN 62281. The transmission interval is 100 ms for the parameter group. The priority level is 6.

Table 25. Fuel Cell Compartment Information.

PGN	PG label	SPN	SP label	Scaling	Range	Length	Startbit
62281	FCCI	21336	Fuel Cell Enclosure 1 Hydrogen Concentration	500 ppm per bit	0 to 125 000 ppm	1 byte	0
62281	FCCI	21337	Fuel Cell Enclosure 2 Hydrogen Concentration	500 ppm per bit	0 to 125 000 ppm	1 byte	8
62281	FCCI	21338	Fuel Cell Compartment Hydrogen Concentration	500 ppm per bit	0 to 125 000 ppm	1 byte	16

The gaseous fuel leakage concentration as percentage of the gas mix, i.e. **not** relative to the lower explosion limit. Values are provided in 1 byte parameters, with a scaling of 500 ppm per bit, which results in an upper bound of 125 000 ppm.

C.5.3.16 Hydrogen Exhaust Concentration

Direction: From FCCU to VCU

This is an optional message

The concentration of hydrogen in the exhaust from the fuel cell needs to fulfill the requirements in the regulations. This message can be used to provide measurements of the hydrogen concentration from a sensor at the exhaust.

Mapping to J1939

The Hydrogen Information parameter group, PGN 63971, is used. It is transmitted every 100 ms with priority level 3.

Table 26. Hydrogen Information.

PGN	PG label	SPN	SP label	Scaling	Range	Length	Startbit
63971	H2INF	23395	Hydrogen Information CRC	1 count per bit	0 to 255 count	1 byte	0
63971	H2INF	23396	Hydrogen Information Counter	16 states	0 to 15	4 bits	8
63971	H2INF	23397	Hydrogen Concentration	500 ppm per bit	0 to 125 000 ppm	1 byte	16
63971	H2INF	23398	Hydrogen Concentration Preliminary FMI	32 states	0 to 31	5 bits	24

The parameter that is used is the hydrogen concentration, SPN 23397. The concentration is signaled with a single byte and a scaling of 500 ppm per bit which results in a range from 0 to 125 000 ppm.

C.5.3.17 FCM Hydrogen Pressure

Direction: From FCCU to VCU

This is an optional message.

Monitoring of hydrogen pressure may be implemented on the FCM and can be used both for leakage detection and status monitoring. The message has room for pressure values from multiple sensors which may be placed at different locations which should be defined by the FCM manufacturer.

Mapping to J1939

This message is implemented using the Fuel Cell System Hydrogen Pressure. The parameter group will be transmitted every 100 ms, with priority 3.

Table 27. Fuel Cell System Hydrogen Pressure.

PGN	PG label	SPN	SP label	Scaling	Range	Length	Startbit
62338	FCSHP	23852	FCSHP CRC	1 count per bit	0 to 255 count	1 byte	0
62338	FCSHP	23853	FCSHP Counter	16 states	0 to 15	4 bits	8
62338	FCSHP	23854	Fuel Cell System Hydrogen Inlet Pressure	0.125 kPa per bit	0 to 8031.875 kPa	2 byte	16

The pressure is signalled using a 2 byte parameter.

The resolution is 0.125 kPa per bit which results in an upper bound of 8031.875 kPa.

C.5.3.18 Alarm Messages

Direction: From FCCU to VCU

The principle used for the alarm messages follows the method used by SAE J1939, i.e. that the active faults include the severity and an indication of the function or component with the fault. The alarms are tied to the parameters that are used in the protocol. The exact use of the alarm messages for root cause analysis etc. is left to the implementation of each FCM.

Mapping to J1939

The alarm messages are implemented using the parameter group Active Diagnostic Trouble Codes in J1939. This is known as Diagnostic Message 1, which indicates the active fault messages at any time.

Table 28. Diagnostic message 1.

PGN	PG label	SPN	SP label
65226	DM1	987	Protect Lamp
65226	DM1	624	Amber Warning Lamp
65226	DM1	623	Red Stop Lamp
65226	DM1	1213	Malfunction Indicator Lamp
65226	DM1	3041	Flash Protect Lamp
65226	DM1	3040	Flash Amber Warning Lamp (AWL)
65226	DM1	3039	Flash Red Stop Lamp (RSL)
65226	DM1	3038	Flash Malfunction Indicator Lamp
65226	DM1	1214	Suspect Parameter Number
65226	DM1	1215	Failure Mode Identifier
65226	DM1	1216	Occurrence Count
65226	DM1	1706	SPN Conversion Method

Details of the use of specific combinations of SPNs, FMIs and lamps are defined by the manufacturers and OEMs. However, some guidelines are described here.

C.5.3.18.1 Lamp SPNs

For the lamp status SPNs (987, 624 and 623) the values are:

00b = lamp off

01b = lamp on

The malfunction indicator lamp (SPN 1213) should not be used, because it has to do with the legal requirements on exhaust emissions. Fuel cells are not part of these legislation.

For warnings that do not require the vehicle to stop immediately, the amber warning lamp (SPN 624) should be used. This can be used when the FCM need to stop but the rest of the system (e.g. vehicle) can continue to operate with another power source.

The protect Lamp (SPN 987) can be used for problems of the fuel cell not related to the electronic part.

The red stop lamp (SPN 623) shall only be used for severe conditions that requires the system (e.g. the vehicle) to stop.

C.5.3.18.2 Suspect Parameter Number

The use of the SPNs in the DM1 is mainly left to the FCM manufacturer because of the need to handle the internal layout and technologies. However, the following guidelines are recommended:

- 1 If a problem can be reported with a standard SPN in a certain Parameter Group (PGN 0 – PGN 65279), that SPN need to be used first
- 2 If a problem can be reported with a standard SPN that is not linked to a certain Parameter Group, that SPN need to be used.
- 3 If a problem will be reported with a FMI = 14, then the range 611 – 615 need to be used. These SPNs are system diagnostic codes defined by the manufacturer and used for failures that cannot be tied to a specific component.
- 4 If a problem cannot be reported with the first 3 rules, then the proprietary range need to be used. The SPNs that are reserved for proprietary diagnostics are 516096 to 524287, i.d. a range of 8192 SPNs.

C.5.3.18.3 Fault Mode Indicator

The fault mode indicators that can be used in SPN 1215 are as listed in Table 29. For more information refer to the annex of J1939/73.

Table 29. Fault mode indicators.

FMI	Description
0	High – most severe (3)
1	Low – most severe (3)
2	Erratic, Intermittent, or Incorrect
3	Voltage Above Normal
4	Voltage Below Normal
5	Current Below Normal
6	Current Above Normal
7	Not Responding Properly
8	Abnormal Frequency, Pulse Width, or Period
9	Abnormal Update Rate
10	Abnormal Rate of Change
11	Other Failure Mode
12	Failure
13	Out of Calibration
14	Special Instruction
15	High – least severe (1)
16	High – moderate severity (2)
17	Low – least severe (1)
18	Low – moderate severity (2)
19	Data Error
20	Data Drifted High
21	Data Drifted Low
22-30	Reserved
31	Condition exists

C.5.3.19 HV Input Power Request

Direction: From FCCU to VCU

This is an optional message.

This message is used to request ancillary HV power from the system to the FCM. This can be provided through the same HV connector that is used for delivering power from the FCM or a separate HV connector, using this request message. For FCMs that do not use ancillary HV power this message is not needed.

Mapping to J1939

This message is using the Fuel Cell System Operations Request, PGN 62328. It is sent every 100 ms with priority level 6.

Table 30. Fuel Cell System Operations Request.

PGN	PG label	SPN	SP label	Scaling	Range	Length	Startbit
62328	FCSOR	23198	FCSOR CRC	1 count per bit	0 to 255 count	1 byte	0
62328	FCSOR	23199	FCSOR Counter	16 states	0 to 15	4 bits	8
62328	FCSOR	23200	Fuel Cell System High Voltage Power Supply Interlock Command	4 states	0 to 3	2 bits	16

The signal used is the 2-bit Fuel Cell System High Voltage Power Supply Interlock Command, SPN 23200. The values are:

00b = Fuel cell system is not requesting the high voltage power supply to be on.

01b = Fuel cell system is ready for the high voltage power supply to be on.

11b = Don't care/Take no action

C.5.3.20 Hydrogen Supply Request

Direction: From FCCU to VCU

This is an optional message.

This command indicates whether the vehicle's hydrogen valve should be open or shut, to supply H2 to the Fuel Cell System. It can be used to inform the system when the FCM expects H2 supply.

Mapping to J1939

The message is implemented using the Hydrogen Storage System Control Command, PGN 16640. This is sent every 100 ms with priority level 6.

Table 31. Hydrogen Storage System Control Command.

PGN	PG label	SPN	SP label	Scaling	Range	Length	Startbit
16640	HSSCC	23186	Hydrogen Storage System Control Command CRC	0 to 255 count	0 to 160.637 5 %	1 byte	0
16640	HSSCC	23187	Hydrogen Storage System Control Command Counter	0 to 15	0 to 160.637 5 %	4 bits	8
16640	HSSCC	23188	Hydrogen Supply Request	0 to 3		2 bits	12

The parameter that is used is the hydrogen supply request, SPN 23188. The values are:

00b = Hydrogen is not requested

01b = Hydrogen is requested

11b = Don't care / Take no action

C.5.3.21 Hydrogen Supply status

Direction: From VCU to FCCU

This is an optional message.

This message is used to inform the FCM about the status of the hydrogen supply. It is intended to be used in combination with the hydrogen supply request, to enable safe operations with coordination of the fuel cell and the hydrogen supply.

Mapping to J1939

The message is implemented using the Hydrogen Storage System Information, PGN 62326. The message will be sent every 100 ms with priority level 6.

Table 32. Hydrogen Storage System Information.

PGN	PG label	SPN	SP label	Scaling	Range	Length	Startbit
62326	HSSI	23189	Hydrogen Storage System Information CRC	1 count per bit	0 to 255 count	1 byte	0
62326	HSSI	23190	Hydrogen Storage System Information Counter	16 states	0 to 15	4 bits	8
62326	HSSI	23191	Hydrogen Supply Active Status	4 states	0 to 3	2 bits	16

The StasHH standard only uses the signal hydrogen supply active status, SPN 231919. The values are:

00b = Hydrogen is not being provided to the fuel cell system

01b = Hydrogen is being provided to the fuel cell system

10b = Error

11b = Not available

C.5.4 J1939 Signals Summary

The signals that have been defined for the protocol from J1939 are listed in Table 33 and Table 34, with the optional parameter groups shaded in grey. For most of the parameter groups the data length has been specified to 8 bytes, even if not all the bits are used in this standard. In addition, there will be 64 header bits as well as bit stuffing added to maintain synchronization, in a worst case scenario the overhead is around 90 bits. Parameter groups that have more than 8 bytes will be sent as multipacket messages using the J1939 transport protocol. The DM1 will be sent each second in case there is at least one active trouble code, and the length depends on the number of active trouble codes. The HVBI may also be sent more often than every second in case of changes in the HV bus availability. The total data rate for one FCM is below 50 kb/s, hence it is possible to have multiple FCMs sharing the same CAN bus.

Table 33. J1939 signals and data rate calculation, FCCU Tx messages. The grey cells are optional messages. Overhead from transport protocol is not included in calculations.

PG	Interval (ms)	Overhead (bit)	Size (bit)	Bitrate (kb/s)
DM1	1000	90	64	0,154
FCSC	5000	90	64	0,0308
FCSCI	10	90	64	15,4
FCSCI1	1000	90	64	0,154
FCSMNPI	100	90	64	1,54
FCSMXPI	100	90	64	1,54
FCSOS	100	90	64	1,54
FCCI	100	90	64	1,54
FCSHP	100	90	64	1,54
FCSOR	100	90	64	1,54
GFI3	500	90	64	0,308
H2INF	100	90	64	1,54
HOURS	0	90	64	
HSSCC	100	90	64	1,54
IC2	500	90	64	0,308
RQST_FCCU	0	90	24	
TPCM_FCCU	0	90	112	
TPDT_FCCU	0	90	64	
			Total	28,6748

Table 34. J1939 signals and data rate calculation, FCCU Rx messages. The grey cells are optional messages. Overhead from transport protocol is not included in calculations.

PG	Interval (ms)	Overhead (bit)	Size (bit)	Bitrate (kb/s)
FCSCC	10	90	64	15,4
FCSVLC	0	90	24	
HVBI	100	90	64	1,54
TD	0	90	64	
AMB	1000	90	64	0,154
HSSI	0	90	64	
TCO1	50	90	64	3,08
RQST_VCU	0	90	24	
TPCM_VCU	0	90	112	
TPDT_VCU	0	90	64	
			Total	27.841

C.5.5 Power-up Sequence

When powering up the whole vehicle (truck, train, ship,...), the main controller (VCU) should be aware of the amount and status of the connected FCMs. The VCU will, once supplied with power, start sending its CAN messages.

The standard support triggering of the wake-up procedure of the FCCU by different sources. Either the VCU and FCCU share the same LV supply, so the power on and wake up will be performed simultaneously. The next option would be the hardwired wake-up signal input to the FCCU. If the wake-up signal is inactive the FCCU may listening on CAN for a wake-up signal.

Then, the connected FCCUs will perform a wake-up procedure and, after an initialization phase, start their communication. Once FCCU feedback is processed by the VCU, further power up actions can be triggered if required.

The timeline of this procedure is shown in Figure 21.

The green blocks are indicating signals sent by the main ECU, here called VCU.

The blue blocks are indicating signals sent by the FCCU.

The example values are shown in the orange blocks.

The content in the bright blue blocks are explaining actions or actual states referred to the values.

The procedure is focusing on the main communication, so some signals defined in this document are not considered.

After switching on the LV power, the VCU and FCCU are started. The VCU is waking up the FCCU by LV enable, CAN trigger or a hardwired wakeup signal.

Once powered, the FCCU sends it initial state (0). The VCU sends a standby request (2) to prepare the FCM for power delivery.

When the FCCU is in standby, the VCU requests to start in DC current control mode (10), which will be followed by the FCCU.

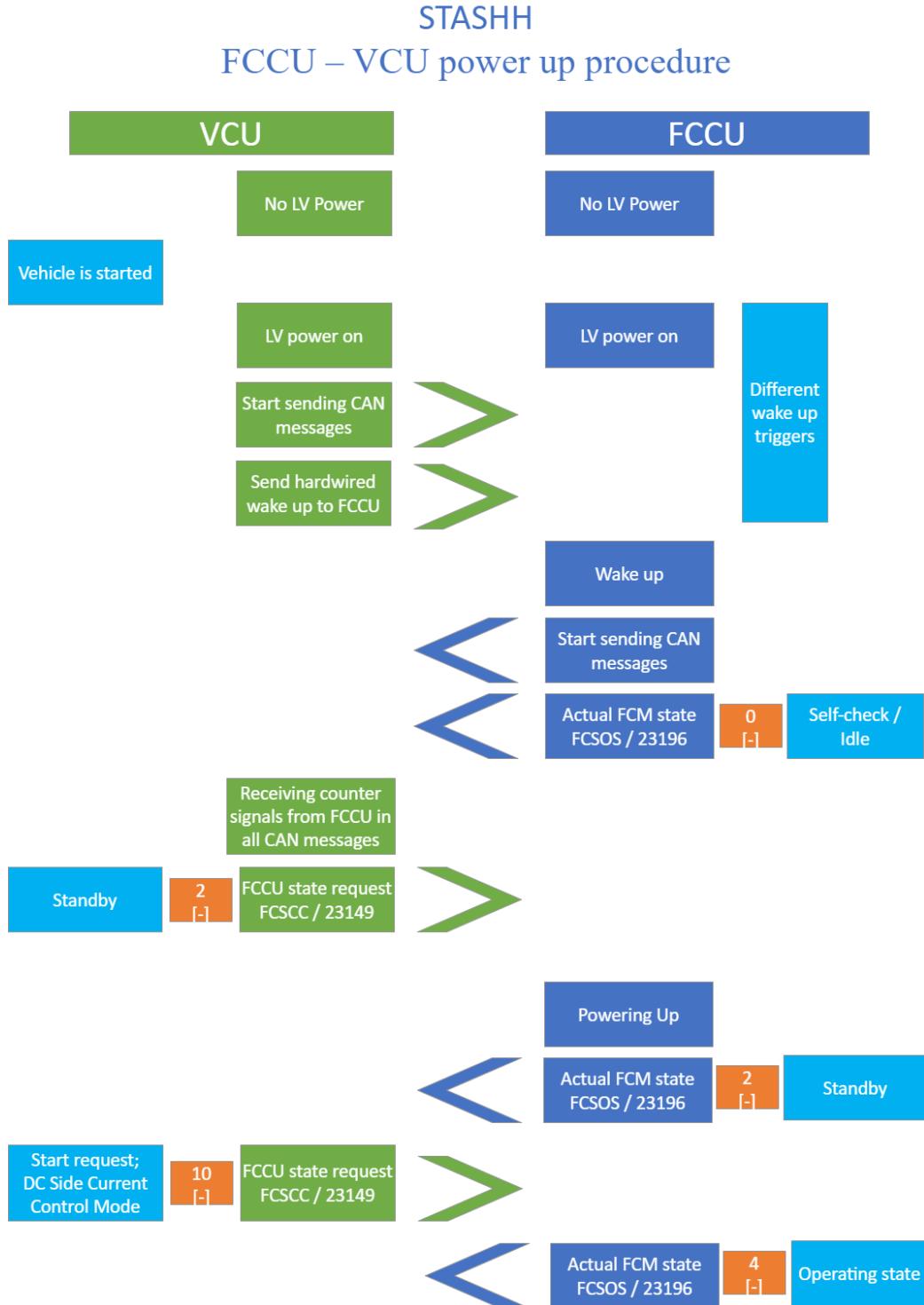

Figure 21. Startup procedure.

C.5.6 Power and State Procedure

In this section an example of the control of the FCMs is provided for illustration of the protocol operation. First, the VCU sends a FCCU state request to start up the FCM. The FCCU will respond with the actual and predicted electrical conditions. Moreover, the maximum and minimum values as reference for the set point are sent to VCU. Based on this feedback and the selected set point unit (by the state request) the VCU will provide a set point for the FCCU.

In the Figure 22 the communication procedure for the power request is shown.

This example continues the previous power up sequence. The electrical values shown in the diagram for indicating the procedure are in dependency of the FCM setup, efficiency, SOH and operating condition.

The FCM is started (10) and the VCU state request is still in the current control mode. It is operating at minimum power (5kW), and providing its respective electrical outputs (10A, 500V). Within the next short period of time the power can be immediately increased to 10kW, but not further decreased (as actual operation is at minimum power to avoid OCV). Also the maximum electrical boundaries are sent to the VCU (500A, 600V, 100kW).

In the next step the VCU is requesting a current setpoint (20%) as of the reference current (500A) from the FCCU.

Now the FCCU increase its power output and feedbacks the actual current (100A).



Co-funded by the European Union

STAS



Towards a standardised fuel cell module

General:
CRC Counter
HV bus availability HVBI / 20802
Emergency stop request FCSCC / 23152 = 5

FCCU – VCU Power & State

General:
CRC Counter
HVIL status FCSOS / 23734

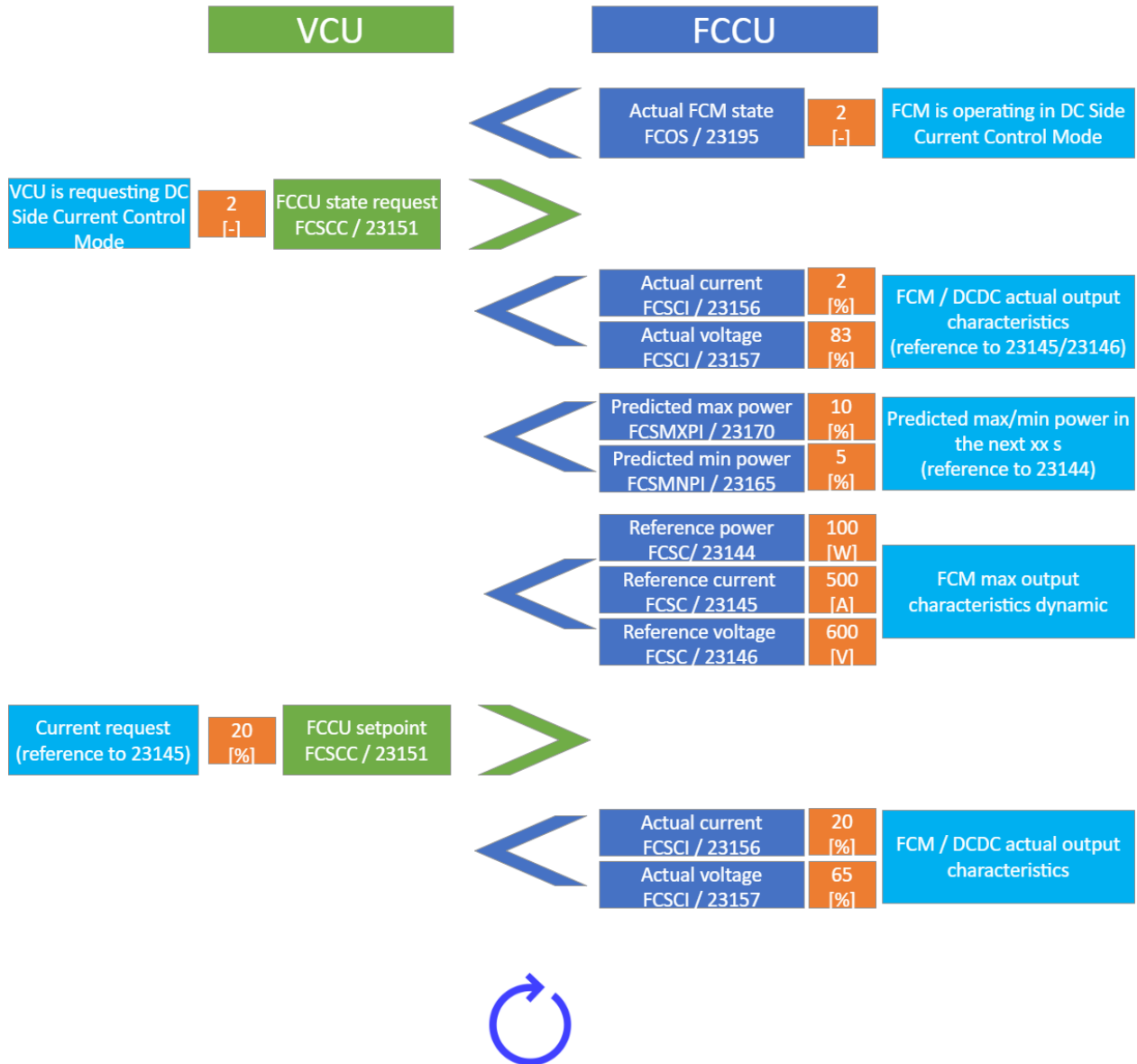

Figure 22. Power and state management.

C.6 Physical Connectors

The physical connector needs to fulfil the requirement of having enough pins to transfer all the electrical signals that are needed. In addition, it needs to be adapted to the working environments of the different application systems.

The following pins are included in the connector:

1. CAN ground
2. CAN high
3. CAN low
4. OPTIONAL shield
5. Wakeup signal
6. Emergency stop

The following optional pins are also specified:

7. OPTIONAL HVIL in
8. OPTIONAL HVIL out
9. OPTIONAL 24V
10. OPTIONAL ground for LV power
11. OPTIONAL CAN high for DC/DC or secondary FCM
12. OPTIONAL CAN low for DC/DC or secondary FCM
13. OPTIONAL CAN high manufacturer specific diagnostic bus
14. OPTIONAL CAN low manufacturer specific diagnostic bus

In addition, it is considered beneficial to include a few additional pins in the connector for future use, and for deployments where additional pins are needed. Therefore, it is recommended to use a connector with four extra pins.

15. Not specified
16. Not specified
17. Not specified
18. Not specified

The proposed pinout can be found in Figure 23.

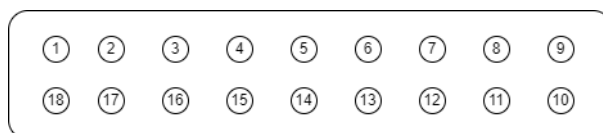

Figure 23. Pinout example.

Since it is difficult to find a suitable connector that fulfils the requirements and is available from multiple sources there is no specific connector required by the standard. The proposal is to use a connector with at least the mandatory pins. A recommendation is to use an 18 pin connector to have the possibility to include additional functions if needed. It is also recommended to use the pin numbers in the list above independent of the type of connector to avoid confusion. I.e. the pin numbering in the list is more important than the example layout in Figure 23.

The main requirement that has been identified is to have an ingress protection level of IP54. However, additional requirements may be coming from different application areas or OEMs. For ships an important requirement is that the cables do not loosen due to vibrations. Therefore, a common solution is to use terminator blocks instead of connectors.

In case the same cable is used for LV power supply, the cable cross-section and current ratings have to be considered. The requirements may differ between different applications due to different cable lengths and regulations for different industries.

For the purpose of testing the FCMs within the StasHH project an example connector is used. This is a heavy duty sealed connector from TE connectivity, with number 1-1564526-1, an 18 pin connector with classification IP67 for ingress protection.



DIMENSIONS

Receptacle Housing			Flanged Tab Housing			Flangeless Tab Housing		
Overall Length A	Overall Height B	Overall Width C	Overall Length D	Overall Height E	Overall Width F	Overall Length G	Overall Height H	Overall Width I
31.3 mm (1.23")	25.7 mm (1.01")	51.2 mm (2.02")	47.1-48.1 mm (1.85-1.89")	39.8 mm (1.57")	62.5 mm (1.46")	47.1-48.1 mm (1.85-1.89")	27.0 mm (1.06")	52.6 mm (2.07")

Figure 24. Example of a compliant connector that is used for the test rigs.

Note that the connector is only specified to handle up to 20 Ampere current, and the power supply through the supply voltage is therefore only intended for the FCCU.

For the connection between primary and secondary FCMs, or between FCM and external DC/DC, the pins for the secondary CAN bus on the same connector is used.



Towards a standardised fuel cell module

C.7 Implementation over Ethernet

This section is for information purpose only. The protocol is intended to be possible to implement also over other types of networks than CAN. In particular, Ethernet is of interest due to its wide adoption and high performance. Implementation directly over Ethernet without IP is not considered, since there is no dedicated Ethertype that can be used to identify the protocol. The Ethertype is encoded in the Ethernet frame header to indicate which protocol is used in the payload of the Ethernet frame, and there is no such code that indicates SAE J1939. Instead, implementation should be over IP and a transport protocol, either TCP or UDP. TCP has the advantage of including mechanisms for reliability, especially CRC, acknowledgement and retransmission. The drawback is the higher complexity to maintain connections between the ECUs. UDP has the advantage of lower complexity and support for multicast transmission but lack reliability functions.

The encoding of the messages defined in Section C.5.3 can be done with each parameter separately or as complete parameter groups. Sending the complete parameter group can be beneficial to keep the implementation as close as possible to the CAN protocol, with straightforward interoperability. Separate parameters provide a simpler handling of parameters in software. In terms of efficiency, sending the full parameter group includes extra bits for parameters that are not used, while it is a more efficient encoding of parameters with less than one byte.

As a guideline, a simple implementation with the complete parameter groups sent over UDP, with the J1939 CRC implemented can be used for implementations where code reuse and integration with CAN bus implementation is needed. An implementation over TCP with separate parameters can be used where it is not expected to interwork with CAN bus implementations.

C.8 Conclusion

This document specifies the StasHH digital interface standard for FCMs. It has been a goal to cover the requirements from different application areas, to make the standard applicable for a wide range of markets. For the physical connector only the basic requirements have been included in the standard. The specific connector is left open to avoid lock-in to a single supplier and to allow for flexibility for different applications that may add new requirements.

The messages have been defined with mappings to J1939 in order to reuse established standards as much as possible. This is convenient in particular for the trucks, buses and other vehicles that already use J1939. Following the guidelines from SAE existing messages have been reused as much as possible. The standard has primarily used the Fuel Cell Systems parameter groups, but some additional parameter groups have been added to cover information that may be needed. Since the design of the FCMs and systems is likely to have a significant variation several parameter groups have been made optional.

The standard is also intended to be useful over other networks than CAN, in particular Ethernet. This will be implemented over IP and TCP or UDP. The details of such implementation is left as future work.



Towards a standardised fuel cell module

List of Tables

Table 1: Fundamental FC module dimensions. The expected rating is only indicative and not a standard-mandated minimum. 7

Table 2: Derived FC module dimensions. The expected rating is only indicative and not a standard-mandated minimum. 7

Table 3: ABC applications 11

Table 4: Mandatory Requirements 13

Table 5 (3 Sections): KPIs for different applications (still as draft) 14

Table 6: Dimensions FC module Interface areas (1st Side). 18

Table 7: Dimensions FC module Interface area’s (Optional 2nd Side). 19

Table 8: Hydraulic and Pneumatic Interfaces FC module. 20

Table 9. UDS services supported by the StasHH standard. 33

Table 10. Parameter group Fuel Cell System Control Command. 38

Table 11. Fuel Cell System Operating State (FCSOS), the grey elements are part of the reused J1939 PG but are not used in the FCM standard. 39

Table 12. Fuel Cell System Configuration. 41

Table 13. Fuel Cell System Controller Information 42

Table 14. Fuel Cell System Minimum Power Information. Grey elements are part of the reused J1939 PG but are not used. 43

Table 15. Fuel Cell System Maximum Power Information. Grey elements are part of the reused J1939 PG but are not used. 43

Table 16. Fuel Cell System Voltage Limit Command. 44

Table 17. High Voltage Bus Information. Grey elements are part of the reused J1939 PG but are not used. 45

Table 18. Fuel Cell System Coolant Information 1. 46

Table 19. Intake/Exhaust Conditions 2. 47

Table 20. Fuel Information 3 (Gaseous). 48

Table 21. Operating Hours of Fuel Cell Module. 49

Table 22. Time/Date parameter group. 49

Table 23. Ambient Conditions parameter group. Grey elements are part of the reused J1939 PG but are not used. 50

Table 24. Tachograph parameter group. The grey elements are part of the reused J1939 PG but are not used in the FCM standard. 51

Table 25. Fuel Cell Compartment Information. 52

Table 26. Hydrogen Information. 53

Table 27. Fuel Cell System Hydrogen Pressure. 54

Table 28. Diagnostic message 1. 55

Table 29. Fault mode indicators. 56

Table 30. Fuel Cell System Operations Request. 57

Table 31. Hydrogen Storage System Control Command. 58

Table 32. Hydrogen Storage System Information. 59

Table 33. J1939 signals and data rate calculation, FCCU Tx messages. The grey cells are optional messages. Overhead from transport protocol is not included in calculations. 60

Table 34. J1939 signals and data rate calculation, FCCU Rx messages. The grey cells are optional messages. Overhead from transport protocol is not included in calculations. 61



Towards a standardised fuel cell module

List of Figures

Figure 1: StasHH’ specific objectives and their contribution to the overall objective 5

Figure 2: Key Terminology..... 6

Figure 3: FC modules: A, B and C base and derived form factors 9

Figure 4: A and AA on their side 10

Figure 5: BBB in engine bay (Example)..... 10

Figure 6: Example BoL and EoL curves 13

Figure 7: Example Bus and GenSet..... 15

Figure 8: StasHH’s specific objectives and their contribution to the overall objective 16

Figure 9: Key Terminology..... 17

Figure 10: Top view FC module 18

Figure 11: FC module interface areas possibilities (1st side) 18

Figure 12: 2 examples FC module interface areas (1st side and optional 2nd side) 20

Figure 13: Non-interfering hydraulic and pneumatic connections 21

Figure 14: Example of HV interface connector 22

Figure 15: Example Bus and GenSet..... 22

Figure 16. Layered concept of the digital interface. 24

Figure 17. FCMs on a shared CAN bus..... 29

Figure 18 Primary - secondary configuration of FCMs. 30

Figure 19. The FCM includes the DC/DC converter from a logical perspective. 31

Figure 20. State machine of the FCM. The numbers refer to the values used in the request and state feedback messages..... 36

Figure 21. Startup procedure. 62

Figure 22. Power and state management. 64

Figure 23. Pinout example..... 65

Figure 24. Example of a compliant connector that is used for the test rigs. 66